

Use, misuse and extensions of “ideal gas” models of animal encounter

John M. C. Hutchinson^{1,*} and Peter M. Waser²

¹Max-Planck-Institut für Bildungsforschung, Lentzeallee 94, 14195 Berlin, Germany and School of Biological Sciences, University of Bristol, Bristol, BS8 1UG, UK

²Department of Biological Sciences, Purdue University, W. Lafayette, IN 47907, USA

(Received 10 November 2005; revised 26 February 2007; accepted 12 March 2007)

ABSTRACT

Biologists have repeatedly rediscovered classical models from physics predicting collision rates in an ideal gas. These models, and their two-dimensional analogues, have been used to predict rates and durations of encounters among animals or social groups that move randomly and independently, given population density, velocity, and distance at which an encounter occurs. They have helped to separate cases of mixed-species association based on behavioural attraction from those that simply reflect high population densities, and to detect cases of attraction or avoidance among conspecifics. They have been used to estimate the impact of population density, speeds of movement and size on rates of encounter between members of the opposite sex, between gametes, between predators and prey, and between observers and the individuals that they are counting. One limitation of published models has been that they predict rates of encounter, but give no means of determining whether observations differ significantly from predictions. Another uncertainty is the robustness of the predictions when animal movements deviate from the model's assumptions in specific, biologically relevant ways. Here, we review applications of the ideal gas model, derive extensions of the model to cover some more realistic movement patterns, correct several errors that have arisen in the literature, and show how to generate confidence limits for expected rates of encounter among independently moving individuals. We illustrate these results using data from mangabey monkeys originally used along with the ideal gas model to argue that groups avoid each other. Although agent-based simulations provide a more flexible alternative approach, the ideal gas model remains both a valuable null model and a useful, less onerous, approximation to biological reality.

Key words: *Cercopithecus albigena*, contact duration, encounter rate, fertilization kinetics, home range, line transect, mangabey, predation rate, search theory, random walk.

CONTENTS

I. Introduction: a history of repeated rediscovery	336
II. Derivation of basic results	338
(1) The ideal gas model	338
(2) Associations versus encounters; counts and durations of associations	339
III. Analytically tractable complications: deviations from model assumptions about detection distance, density, speed and direction	341
(1) Detection distance	341
(2) Density	341
(3) Speed	342
(4) Direction	343

* Address for correspondence: John Hutchinson, Privat, Staatliches Museum für Naturkunde Görlitz, PF 300154, 02806 Görlitz, Germany. Tel: +49-3581-4760410 Fax: +49-3581-4760499. Email: majmch@googlemail.com

IV. Tracks that are not straight	343
(1) Monte-Carlo simulations	344
(2) Correlated random walks	344
(3) Rebounds	344
(4) Other forms of non-independence	346
V. Corrections of some errors in the literature	346
(1) Encounter duration	346
(2) D for spread-out groups	347
(3) Partial overlap of home ranges	347
(4) Infanticide rate	348
(5) Mating benefits of an increased home range	349
(6) Spiral trajectories of sperm	349
(7) Predation in the plankton	349
(8) Estimating seabird densities from ship- and aircraft-based counts	351
VI. How to test the predictions?	352
VII. An example: grey-cheeked mangabey intergroup encounters reanalysed	353
VIII. Discussion	355
IX. Conclusions	356
X. Acknowledgements	356
XI. References	356

I. INTRODUCTION: A HISTORY OF REPEATED REDISCOVERY

In 1860, the physicist James Clerk Maxwell worked out the expected rates of collision among molecules in an ideal gas, given the concentration of molecules in the gas, their mean speed, and their “cross section”, a measure of their size. His formula assumes that the movements of the molecules are independent, equally likely in all directions, and with speeds drawn from a “Maxwell-Boltzmann” distribution [i.e. the x and y components of their velocities are normally distributed: e.g. Maxwell (1860); Kauzmann (1966, chapter 5)]. These assumptions have proven attractive to biologists, who have repeatedly rediscovered Maxwell’s approach in constructing models of encounter rates between moving animals. The image of moving animals as molecules has proven equally appealing, and in the biological literature the term “ideal gas model” has come to be attached to ideas that have developed from these assumptions.

One biological use of the ideal gas approach is as a null model. For example, Waser (1975) used it to detect cryptic behavioural attraction between adults in a “solitary” antelope species. Because observed rates of encounter among individual bushbuck (*Tragelaphus scriptus*) were an order of magnitude higher than expected if bushbuck behaved like gas molecules in a two-dimensional bottle, he argued that individual movements were not independent. Waser (1976) subsequently applied the same null model to detect cryptic cases of behavioural avoidance between social groups of grey-cheeked mangabeys (*Cercocebus albigena*). Mitani *et al.* (1991) used the approach to show that encounter rates and association durations among some classes of orang-utans (*Pongo pygmaeus*) were greater than expected by chance. Similarly Schülke & Kappeler (2003) and Gursky (2005) working on prosimians (*Tarsius spectrum* and *Phaner furcifer*) demonstrated associations between members of social pairs that had usually been considered to forage solitarily. Barrett

& Lowen (1998) and Sugiura *et al.* (2000) have used the ideal gas model to ask why patterns of interanimal spacing sometimes differ among primate populations at different densities. Do individuals change their behaviour with density, or is it simply that encounter rates change with density, and the same behavioural rules expressed at different rates of encounter produce different spacing patterns?

Ideal gas models are readily generalized to investigate patterns of encounter between, as well as within, species. Thus Crowley *et al.* (1991) used this approach twice in the same model of mating choosiness, once for encountering predators and once for encountering mates. Waser (1982, 1984, 1987) used the ideal gas model to generate null predictions regarding the frequency and duration of mixed-species primate associations. Several other investigators (Cords, 1987; Whitesides, 1989; Hohenweg, Noë & Schabel, 1996) have subsequently used this approach.

In most of the above examples, and others (e.g. De Vita, Kelly & Payne, 1982), the ideal gas model provides a null hypothesis and interest focuses on deviations from its predictions. In other cases, ideal gas assumptions are used to estimate encounter rates as a component of some larger model. For example, Rowcliffe, Cowlishaw & Long (2003) recently modelled the effect of human hunting on mammalian population density assuming that prey individuals encounter snares at rates predicted using ideal gas logic. Jetz *et al.* (2004) modelled how home range size scales with body size, assuming that the proportion of resources lost to neighbours is related to encounter rate; the ideal gas model enabled the scaling of encounter rate to be estimated from the known scaling relationships of speed of movement, population density, and detection distance.

One context in which the ideal gas model has often been applied is mate finding. Mosimann (1958) analysed the probability of a female encountering no males during the breeding season in low-density populations. In effect, he quantified the suggestion of Allee (1938) that populations

below some minimum density would decline because of the difficulty of finding mates. Katona (1973) modelled the effect of diffusible sex pheromones in reducing the time taken for planktonic copepods to find mates. Manica & Johnstone (2004) estimated the reduction in a male bug's encounter rate with females if he stopped moving around so as to be able to guard a brood. Similarly, a series of primatology papers have applied the ideal gas model to compare mating success of a roving polygamous strategy with that of monogamy (van Schaik & Dunbar, 1990; Dunbar, 1995, 2000). Another application was to estimate infanticide rates in great apes, under the assumption that infanticide occurs if a male fails to encounter the female during oestrus, but does encounter her while she is nursing (Harcourt & Greenberg, 2001).

In the field of fertilization kinetics, and particularly concerning the issue of the evolution of anisogamy, Scudo (1967, p. 285) noted that "the adaptive value of various modes of reproduction can be studied...using the same tools which classical statistical mechanics applies to the collision of particles". Research in this field continues to be active (Randerson & Hurst, 2001; Dusenbery, 2002, 2006), with most models taking as their starting point the ideal gas model of encounter rate (e.g. Vogel *et al.*, 1982; Cox & Sethian, 1985; Dusenbery, 2000). One issue of recent interest is the function and optimal thickness of the jelly coat around some eggs; it increases target size but tends to decrease sinking speed, which the gas model predicts to have opposite, although unequal, effects on encounter rate with sperm (Farley & Levitan, 2001; Podolsky, 2002).

Lotka (1924, p. 358) derived the mean free path of a predator (the distance moved between successive encounters with prey) from "the elementary kinetic theory of gases". He went on to show that the frequency of predator-prey encounters should be proportional to predator speed and "size", and to population densities of predator and prey, using this result to justify the multiplicative form of the predator-prey encounter term in his famous equation. Laing (1938), following Stanley (1932), used the same approach to show that parasitoids found hosts at too high a rate to be explained by random movement, generating one of the first quantitative arguments in evidence of area-restricted search. Gerritsen & Strickler (1977) re-derived formulae for encounter rates in three dimensions and these have had "...considerable influence in subsequent studies of plankton feeding" (Evans, 1989, p. 415). One instance is understanding rates and size-selectivity of predation on the larvae of commercially significant fish (e.g. Fuiman & Gamble, 1989; Paradis & Pepin, 2001). Letcher *et al.* (1996) modelled predation and starvation in larval fish using the ideal gas model twice, to calculate encounter rate with both its predators and prey.

In a quite different context, Yapp (1956) suggested that "...encounters between a moving observer and the individuals of a mobile species could be likened to the collisions between a molecule of one kind and molecules of another". Accordingly, Yapp (1956) and Skellam (1958) applied the encounter-rate equation in reverse, to estimate the density of a target species from the number of times an observer walking a line transect encounters the species,

taking into account the observer's speed, the average speed of target individuals, and the distance at which the observer can detect them. Estimates of seabird numbers are often made from such data collected from ships or aircraft, but curiously the literature seems to have largely lost sight of the ideal gas approach. The modern theory of "distance sampling" (Buckland *et al.*, 2001) also estimates density from transect data and has become a rather sophisticated technique, but it assumes that the targets are stationary (and claims reasonable accuracy only if they move at less than half the speed of the observer: Buckland *et al.*, 2001, p. 31). Gaston & Smith (1984) and Spear, Nur & Ainley (1992) independently redeveloped some aspects of the ideal gas model to correct for biases when the birds predominantly fly in a particular direction.

"Search theory", originally developed to optimize the search for submarines during World War II, leads to the same encounter-rate predictions as ideal gas models in the null case of randomly moving searchers and randomly moving targets (Koopman, 1956; Dusenbery, 1992). This literature was the inspiration for biologists to apply the ideal gas model in a variety of situations: encounters between zooplankton predators and phytoplankton prey (Gerritsen & Strickler, 1977), the effect of prey aggregation on risk of predation (Olson, 1964; Kiltie, 1980), encounters among gametes of aquatic plants (Cox, 1983), and the evolution of parthenogenesis in sparse populations (Gerritsen, 1980*b*).

During this long history of repeated rediscovery, two limitations of the ideal gas approach have surfaced. First, while many authors have developed similar approaches to estimating expected encounter rate, there has been little discussion of the confidence limits on the estimates (but see Skellam, 1958). Thus it has not been the practice to compare observations with predictions in a rigorous statistical way (Schülke & Kappeler, 2003, provide an exception).

Second, the "random movement" assumption seems unrealistic in many biological applications. This limitation was noted by Lotka (1924, p. 360) in what was apparently the first discovery of the ideal gas model by a biologist: "...the type of motion presented by living organisms [unlike that shown by ideal gas molecules]...can be regarded as containing both a systematically directed and also a random element...mathematical treatment...may appear to threaten formidable difficulties. It is to be hoped that this will not altogether prevent its attack."

Maxwell's model of an ideal gas may fit the movements of dilute gas molecules rather closely, but animals' movements are almost certain to deviate from the assumptions in some significant ways. In an ideal gas, molecules are randomly distributed, move long distances in straight lines between encounters, and the size of the bottle that contains them is relatively very large. By contrast, real animals may spend more time in some habitats than others, deviate frequently from straight lines, and be restricted to partially overlapping home ranges. Animal populations may further violate the assumptions by showing anisotropy in the directions of movement, or by the speeds not following a Maxwell-Boltzmann distribution. Biologists need to know whether such violations change the rate of encounter substantially, and, if so, they might want to measure the relevant char-

acteristics of the paths of real animals so as to incorporate these parameters into more sophisticated models.

The goals of this paper are to review the basic results of ideal gas models of animal encounter, to examine the sensitivity of model predictions to some simple, but probably common, deviations of real animals from model assumptions, and to illustrate how some of these complications can be incorporated into the models. In addition, we correct a number of errors in this literature, describe how to estimate confidence limits on encounter rates, and illustrate our approaches by reanalyzing the data set used by Waser (1976) in his early application of the ideal gas model to interactions among primate groups.

II. DERIVATION OF BASIC RESULTS

(1) The ideal gas model

In this section we state the standard analytic results from the ideal gas model. Strictly speaking, the “ideal gas model” applies only to molecules moving in three dimensions with a Maxwell-Boltzmann distribution of speeds and colliding inelastically, but we will follow the biological literature in applying the phrase more generally. So assume initially that individuals are moving independently at constant speed v , in a plane, in straight lines oriented randomly with a uniform distribution. We focus on one individual and it is helpful to consider the motion of all other individuals relative to that focal individual (Fig. 1); in this perspective, the focal individual appears stationary. By integrating over all possible angles between the directions of movement, one can calculate (Fig. 1) that the mean speed of the other individuals relative to the focal individual is

$$4v/\pi. \tag{1}$$

We consider that two individuals encounter each other if their centres approach within a detection distance D . We assume that contact does not change their speed or direction. Each non-focal individual sweeps out a strip $2D$ wide (Fig. 1C) such that if the focal individual lies within the strip an encounter occurs (remember that we are viewing motion relative to the “stationary” focal individual). In time t the area swept out by each individual is on average $2D \times 4v/\pi \times t$. If the density of individuals is ρ , an area A should contain on average ρA individuals; these will have swept out strips of total area $\rho A \times 8Dvt/\pi$. The number of randomly positioned strips (=individuals) that cover the focal individual follows a Poisson distribution, with mean $(\rho A 8Dvt/\pi)/A = 8\rho Dvt/\pi$. Thus the expected number of encounters after moving a distance x is $8\rho Dx/\pi$, and an individual’s encounter rate is

$$8\rho Dv/\pi. \tag{2}$$

The Poisson distribution of encounter number implies that the probability that an individual has no encounters in time t is

$$\exp(-8\rho Dvt/\pi), \tag{3}$$

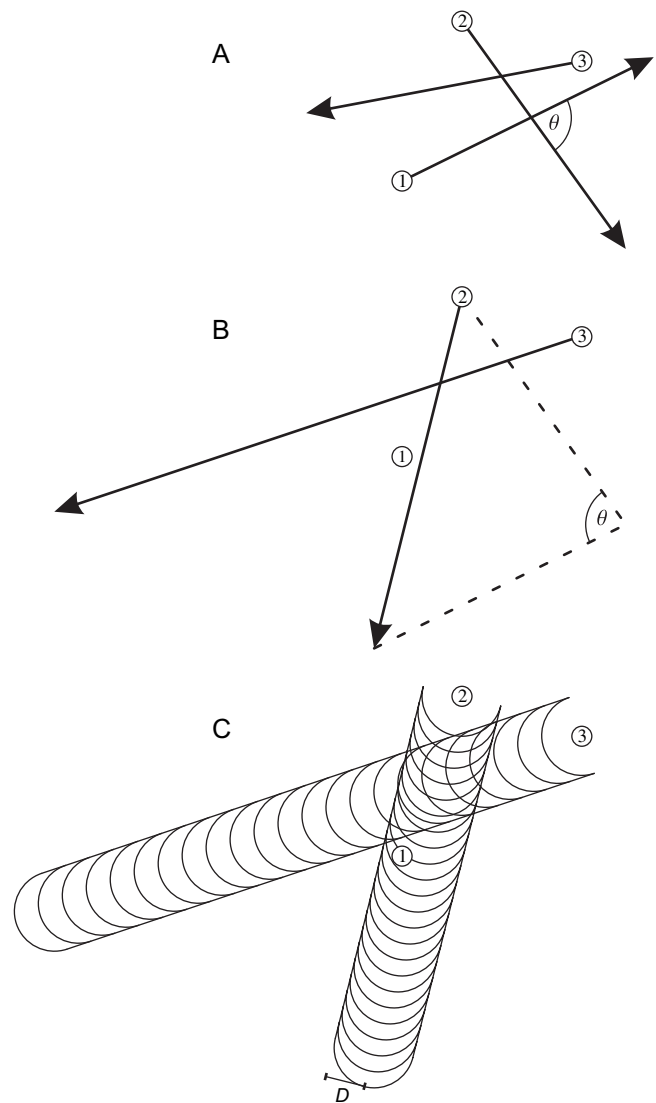

Fig. 1. (A) Trajectories of three individuals, each travelling at the same speed v , over a period t , so the length of each trajectory is vt . (B) The same trajectories as in A but viewed relative to the position of individual 1, which thus now appears to remain in the same spot. The dashed lines are the translated vectors of individuals 1 and 2 from A used to construct the relative trajectory of individual 2 (solid line); the length of this relative trajectory is $2vt \sin(\theta/2)$ (since the dashed lines form an isosceles triangle with it). (C) The areas swept out by the leading edge of a disc of radius D following the trajectories of individuals 2 and 3 relative to 1. This shows that individual 1 comes within D units of individual 2 but never so close to individual 3. The probability of an encounter with the focal individual depends on the size of this swept-out area, which for individual 2 is $2D \times 2vt \sin(\theta/2)$. The average area for a randomly orientated individual (i.e. θ evenly distributed between 0 and π) is thus $2D \times 2vt \int_0^\pi \sin(\theta/2) d\theta/\pi = 2D \times 4vt/\pi = 8Dvt/\pi$. The $4vt/\pi$ term is the mean relative speed.

which can be subtracted from 1 to give the probability of at least one encounter. Since encounters are random and independent, the time between encounters has an exponential distribution, with the mean interval between initial contacts given by the reciprocal of the encounter rate:

$$\pi/(8\rho Dv). \tag{4}$$

The mean distance between initial contacts (mean free path) is speed \times mean interval $= \pi/(8\rho D)$. If we are concerned with the total number of encounters in an area A , we can multiply the individual encounter rate by the mean number of animals in the area (ρA) divided by 2 (because each encounter is experienced by two individuals), giving the expected number of encounters as

$$4\rho^2 ADvt/\pi. \tag{5}$$

So far we have assumed that the focal individual is the same as any of the other individuals that it encounters, but the ideal gas model has often been applied to encounters between different classes (e.g. sexes) of individuals. In that case the encounter-rate formula describes the number of encounters of an individual of one class if ρ refers to the density of the other class. For the total number of interclass encounters within an area A , simply replace the term ρ^2 in (5) by $\rho_a\rho_b$, the product of the densities of each class (*cf.* the law of mass action from chemistry). When the classes move at different speeds, the $4v/\pi$ term for mean relative speed must also be modified, as discussed in the next section.

We have been predicting encounter rate assuming knowledge of density, detection distance and speed. Sometimes we might measure encounter rate and want to estimate one of the other variables, such as when seeking to estimate population density of pelagic seabirds from the number seen from a ship. Similar strategies could be used as rules-of-thumb by non-human animals. For instance, Pratt (2005) shows how ants (*Temnothorax albipennis*) deciding between two nest sites change their behaviour when a critical quorum of scouts agree on one site, and this is apparently sensed by encounter rate with other ants. When the number of encounters counted is large, it is sufficient simply to rearrange the above formulae to achieve the estimation of density from observed encounter rate. But when few encounters have been observed one should specify a prior distribution of encounter rates and use a Bayesian approach to estimate the true encounter rate. A uniform prior may not be the most appropriate; in the absence of further knowledge, for a Poisson-distributed variable (like number of encounters) with mean μ there are theoretical arguments in favour of a prior distribution with density proportional to $\mu^{-0.5}$ (Jeffreys, 1961, p. 186). Then, if we have observed n encounters over a time t , an unbiased estimate of density is calculated from an encounter rate of $(n + 0.5)/t$, rather than n/t .

It is straightforward to extend these lines of argument to apply to three dimensions. In that case the mean relative speed is

$$4v/3 \tag{6}$$

(Fig. 2). The trajectory of each individual relative to the focal individual sweeps out a bullet-shaped solid with the same volume as a cylinder of radius D and length $4v/3 \times t$. So its volume is $\pi D^2 \times 4vt/3$, and the focal individual's expected encounter rate is

$$4\pi\rho D^2v/3. \tag{7}$$

Physicists have also derived equations for the rate at which molecules of an ideal gas hit the walls of a container (rate $= \rho v/4$ per unit area; Kauzmann, 1966, p. 179); the two-dimensional analogue giving hits per unit length is

$$\rho v/\pi, \tag{8}$$

which has been applied by Lowen & Dunbar (1994) to analyse the defendability of primate territories of different sizes.

(2) Associations versus encounters; counts and durations of associations

The ideal gas model predicts the number of *initiations* of encounters in time t . Thus when testing predictions one

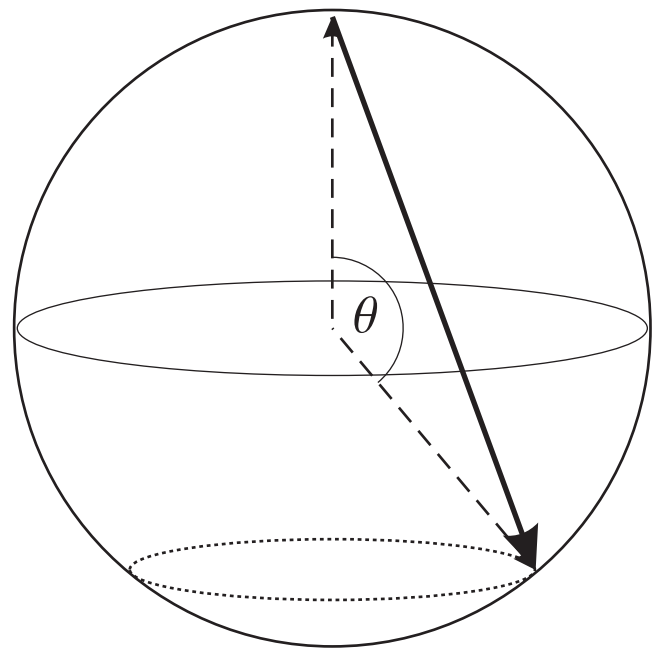

Fig. 2. Mean relative speed in three dimensions. Dashed lines show the directions of two individuals at an angle θ to each other; without loss of generality the focal individual is shown vertically orientated. The trajectory of the other individual relative to the focal individual (thick solid line) has length $2vt \times \sin(\theta/2)$, as in the two-dimensional case (Fig. 1). However, randomly orientated individuals now yield some values of θ more commonly than others: the probability of the angle lying between θ and $\theta + \delta\theta$ is the area of a strip of width $\delta\theta$ following the dotted line on the figure, divided by the surface area of the sphere $= 2\pi \sin \theta \delta\theta/(4\pi) = \sin \theta \delta\theta/2$. Thus the mean length of the relative trajectory is $vt \int_0^\pi \sin(\theta/2) \times \sin \theta d\theta = 4vt/3$.

should ignore encounters that have already started at the beginning of the period of observation. Fewer observed encounters than predicted could occur because individuals either avoid each other or persistently stay within contact (Struhsaker, 1981). If, instead of following an individual animal continuously, one made instantaneous observations of it at n intervals, the expected number of “associations” (i.e. ongoing occurrences of other individuals within a distance D , rather than instances of them crossing into this region) is not given by the ideal gas model. Rather, the appropriate formula in the two-dimensional case is

$$n\rho\pi D^2. \tag{9}$$

This is simply the sum of the areas of $n\rho$ disks of radius D (think of a series of n disks replacing each of the $2D$ -wide strips considered above: Fig 3A). The formula assumes that if on n successive sampling occasions the same pair of individuals are together, that counts as n associations.

Unlike with the rate of encounters, the formula for the number of associations is unaffected by speeds or by non-uniform distributions of directions (cf. Section III). Consequently there are times when this approach may be more appropriate: for example, when estimating seabird densities from counts from ships, it may be simpler and more reliable to make periodic instantaneous counts of numbers occupying an area around the ship than to count the number of new encounters over a period and apply the ideal gas model (e.g. Tasker *et al.*, 1984).

It is important not to confuse the two approaches. Schülke & Kappeler (2003) made counts of observation times (every 5 min) when individuals were in contact, where two consecutive observations of the same individuals in contact were counted as two “encounters”. They should have compared their observations against $n\rho\pi D^2$, not the $8\rho Dvt/\pi$ from the ideal gas model. Likewise, at any single moment of observation, or summed over n such observations, the predicted number of individuals observed between distances $D - \delta D$ and $D + \delta D$ from a focal individual is directly proportional to D for small δD (Fig 3B). By contrast, the ideal gas model predicts that, over a long period of observation, the number whose closest approach lies within this range of distances is a constant independent of D (Fig 3C; cf. Gursky, 2005; different results hold for three dimensions).

At any instant the mean number of other individuals with which an individual is in contact is $\rho\pi D^2$: in comparison with Fig 3A, each non-focal individual now is represented by only one disc. If each individual’s position is independent of the positions of others, how many discs cover the focal individual is Poisson distributed. Thus the probability (or proportion of time) that an individual is in contact with at least one other is

$$1 - \exp(-\rho\pi D^2); \tag{10}$$

this corrects the equations in Whitesides (1989) and Hohenweg *et al.* (1996).

The mean duration of an association is the mean number of contacts at one moment ($\rho\pi D^2$) divided by the rate at

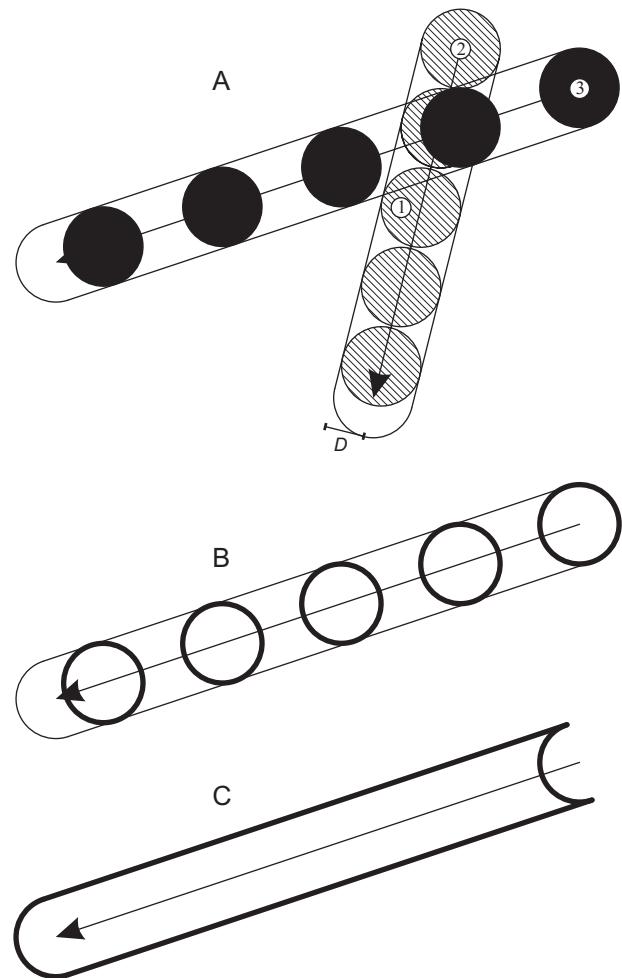

Fig. 3. (A) A modification of Fig 1C to describe the situation when the number of occasions on which an association occurs is counted (instead of the number of new encounters). The expected number of associations is how many discs cover a random spot, and is thus the product of the area of each disc (πD^2), the number of observations made (5 in this example), and the density of individuals. Speed and direction make no difference: the sum of the areas occupied by the discs is the same for individual 2 (hatched) as individual 3 (solid shading). For small values of θ (the angle between trajectories) the relative trajectories are shorter so that the discs overlap (as they are also more liable to do if the sampling interval is short compared to the speeds); an association may then persist from one observation to the next and should then be counted more than once to match with the model. (B) The number of associations between $D - \delta D$ and $D + \delta D$ from a focal individual is given by the area of the annuli (each has area $4\pi D \delta D + \delta D^2 \sim 4\pi D \delta D$ for small δD , and is thus proportional to D). (C) The number of encounters within $D + \delta D$, but not closer than $D - \delta D$ is given by the shaded region. For long periods of observation the semicircles at each end are a minor component, so the area is roughly $4 \delta D \times$ length of relative trajectory, and thus is independent of D .

which encounters occur (given by the ideal gas model). So with constant speeds in two dimensions, mean duration is $\rho\pi D^2/(8\rho D\nu/\pi)$, which simplifies to

$$\pi^2 D/(8\nu). \quad (11)$$

This formula corrects that derived by Waser (1984) and used by others (e.g. Holenweg *et al.*, 1996); see Section V(1).

In three dimensions the mean number of other individuals with which an individual is in contact at any moment is

$$\rho(4/3)\pi D^3 \quad (12)$$

(i.e. the volume of a sphere of radius D around each non-focal individual \times their density), and the mean duration of an encounter is this divided by encounter rate, yielding

$$D/\nu. \quad (13)$$

III. ANALYTICALLY TRACTABLE COMPLICATIONS: DEVIATIONS FROM MODEL ASSUMPTIONS ABOUT DETECTION DISTANCE, DENSITY, SPEED AND DIRECTION

(1) Detection distance

If the detection distance varies over the environment (e.g. because visibility depends on the vegetation), it is still valid to use the mean detection distance in the standard encounter-rate formulae for two dimensions; but obviously the variance in encounter rate will now be higher (the distribution is no longer Poisson). In the three-dimensional case, because of the D^2 term in those formulae, variation in detection distance about the mean does affect mean encounter rate. Calculating the mean square of detection distance sidesteps this complication.

(2) Density

If individuals are distributed patchily so that density is consistently higher in some regions, the mean density can be used in the standard formulae, but again the variance in encounter rate will be higher than for the Poisson distribution. Note that mean density must be calculated by integrating over the time spent in each region, not over area. For instance, suppose that there are two habitats of equal area, and that the population is three times as dense in one habitat, so the densities are 0.5ρ and 1.5ρ . If the focal individual spends equal time in the two habitats, the mean density that it experiences is ρ , so the formula for encounter rate is unchanged. If instead it spends three times as long in the high-density patch (such a tendency in the population might itself have generated the higher density), the mean density that it experiences is 1.25ρ , so the expected encounter rate is increased by a factor of 1.25. If the density is higher in one habitat simply because the animals move more slowly there, then the mean encounter

rates within the two habitats are the same (the product of density and speed is what matters). Gordon, Paul & Thorpe (1993), working on the ant *Lasius fuliginosus*, explained a lower than expected increase in encounter rate with density as resulting from a tendency to aggregate at low densities. Without knowing how the aggregation is produced—reduced speed in the area of aggregation or a reduced tendency to head away from it—one cannot predict whether a tendency to aggregate will affect encounter rate, but there was evidence for the latter mechanism in this example.

The ideal gas model has often been applied when individuals are confined to home ranges. In cases where two individuals share the same home range, their expected encounter rate is obtained by setting $\rho = 1/(\text{home range})$ (e.g. Schülke & Kappeler, 2003). If a male home range is considered to enclose the complete home ranges of several females, his expected encounter rate with them is obtained by setting $\rho = (\text{number of females})/(\text{male home range})$ (e.g. van Schaik & Dunbar, 1990). If home ranges of two individuals overlap only partially, the situation should be analysed as in Section V(3); it is wrong simply to set $\rho = 1/(\text{mean home range size})$ (*cf.* Gursky, 2005).

In some two-class systems an individual disappears from the system after one encounter, as when a sperm sticks to an egg or when a predator meets a prey item and the latter either is eaten or hides. If these disappearing items do not replenish, their density will decrease with time, so that encounter rate also decreases. Suppose that the mean relative speed of predator and prey is w , that the initial density of prey is ρ_p and that of predators ρ_P . The probability of a prey item meeting no predator in time t is

$$\exp(-2w\rho_P Dt), \quad (14)$$

so that in a large area A the number of encounters would be $A\rho_p[1 - \exp(-2w\rho_P Dt)]$ distributed randomly over $A\rho_P$ predators. Hence the mean rate of encounter for a single predator is

$$(\rho_p/\rho_P)[1 - \exp(-2w\rho_P Dt)] \quad (15)$$

and the probability of a predator encountering no prey is

$$\exp(-(\rho_p/\rho_P)[1 - \exp(-2w\rho_P Dt)]). \quad (16)$$

This last formula is particularly relevant in calculating the probability of an egg not having been fertilized by a sperm, an approach developed in Vogel *et al.*'s (1982) ‘‘Don Ottavio’’ model.

A related complication modelled by Nicolis, Theraulaz & Deneubourg (2005) occurs when individuals that have met stay together immobile while they interact, but after some time split up. Such is what often happens in ants. The temporary immobility obviously lowers the encounter rate but Nicolis *et al.* (2005) further showed that with long interaction periods individual encounter rate tends towards being proportional to density^{1/2} rather than the linear relationship of the ideal gas model.

(3) Speed

If individuals vary their speed or if speed varies among individuals, the ideal gas formulae must be amended. In the two-dimensional case, for instance, the term $4\nu/\pi$ must be replaced by a revised mean relative speed between the focal individual and other individuals from the population. To calculate this it is necessary to know the distribution of absolute speeds, not just their means, and then to integrate over the range of speeds of the focal individual, over the range of speeds of the other individuals, and over all possible differences in their directions. The formula thus becomes

$$\int_{u=0}^{\infty} p_u(u) \int_{v=0}^{\infty} p_v(v) \int_{\theta=0}^{\pi} \sqrt{u^2 + v^2 - 2uv \cos \theta} \, d\theta \, dv \, du / \pi, \tag{17}$$

where $p_u(u)$ = probability of the focal individual having speed u , $p_v(v)$ = probability of a non-focal individual having speed v , and θ = the angle between trajectories. The central term is the cosine formula to calculate the length of the third side of a triangle if two sides and the angle between them are known. The extension to three dimensions requires only replacing the factor $1/\pi$ by $0.5 \sin \theta$ within the integral, so as to weight the average according to the non-uniform distribution of θ (Fig. 2). The integration must be done numerically except in some special cases of analytic tractability.

One tractable case, of widespread applicability, occurs when speeds in the population follow a Maxwell-Boltzmann distribution. In the two-dimensional case its probability density function is

$$\frac{2\nu}{r^2} \exp(-(\nu/r)^2), \tag{18}$$

and in the three-dimensional case is

$$\sqrt{\frac{27}{2\pi}} r^{-3} \nu^2 \exp\left(\frac{3}{2}(\nu/r)^2\right), \tag{19}$$

where r = root-mean-square speed. These skewed distributions are reasonable approximations to several observed speed distributions (Okubo, 1980; De Vita *et al.*, 1982; Waser, 1984; Mitani *et al.*, 1991), and are the speed distributions expected if animals are following a fine-scale random walk but speeds are measured on a coarser scale. In a population of animals with a Maxwell-Boltzmann distribution of speeds, the mean relative speed is

$$\sqrt{2}\bar{\nu}, \tag{20}$$

where $\bar{\nu}$ is the mean speed.

This result assumes that each individual's speed is independently drawn from the distribution. Suppose instead that the variation in speed was to a large extent an effect of time of day (for instance, mites running around on a paving stone might all speed up as the temperature increases in the

afternoon). In the extreme case of all individuals travelling at the same speed ν at any particular time of day, the mean relative speed would be $4\nu/\pi$ at any one time and thus $4\bar{\nu}/\pi$ averaged over the whole period.

If we know the speed of the focal individual, we can refine our predictions. This is relevant when calculating encounter rates between two classes of individual, such as predators and prey, that move at different speeds. In many examples one class of individual is stationary (e.g. eggs, when predicting their rate of fertilization by more motile sperm), which simplifies the encounter-rate formula to $2\rho D\bar{\nu}$ for two dimensions, or $\pi\rho D^2\bar{\nu}$ for three dimensions. If the two classes of individual travel consistently at two different non-zero speeds, in three dimensions the encounter rate for an individual of one class is

$$\pi\rho D^2(u^2 + \nu^2/3)/u \tag{21}$$

(e.g. Gerritsen & Strickler, 1977), where ρ is the density of the other class and ν is the speed of whichever class is slower. Unfortunately in two dimensions the term for mean relative speed when $u \neq \nu$ involves an elliptic integral. But if both predator and prey have Maxwell-Boltzmann distributions of speeds, with mean speeds \bar{u} and $\bar{\nu}$, then the mean relative speed is simply

$$\sqrt{\bar{u}^2 + \bar{\nu}^2}. \tag{22}$$

[Skellam (1958) proves this for the two-dimensional case and it also holds in three dimensions; see also Evans (1989) for a neat extension to include turbulence in the media.]

Small inter-individual differences in speed have rather little effect on encounter rate. For instance, Gursky (2005) was interested in contact rates between male and female partners; males moved up to 1.49 times as far as their partners. In that case Gursky's use of the mean speed of partners is liable to underestimate encounter rate by a factor of only 0.95 if each individual's speed was constant, or 0.98 assuming Maxwell-Boltzmann distributions.

An increase in a predator's speed increases its rate of encountering prey; the relationship is approximately linear when the predator moves faster than the prey, but becomes more curved at slower speeds (Fig. 4). This pattern has biologically interesting consequences. For example, in the two-dimensional case, if prey all move with speed ν , and the predator moves at 2ν , the mean relative speed is 2.13ν ; but if the predator moves at $\nu/2$, the mean relative speed is only 1.06ν . So a predator moving at half the speed of its prey gains only a 6% increase in encounter rate over that had it remained motionless, which, supposing some costs to moving, suggests advantages of a sit-and-wait tactic. Gerritsen & Strickler (1977) developed such optimality arguments quantitatively by introducing trade-offs relating speed to power requirements and detection distance. Similarly in the optimality model of Dusenbery (2006) larger gametes benefit from their faster speed (as well as from increased encounter distance and longevity), but fewer can be produced.

Sometimes what matters is the number of encounters not per time, but per distance moved. For instance an auk

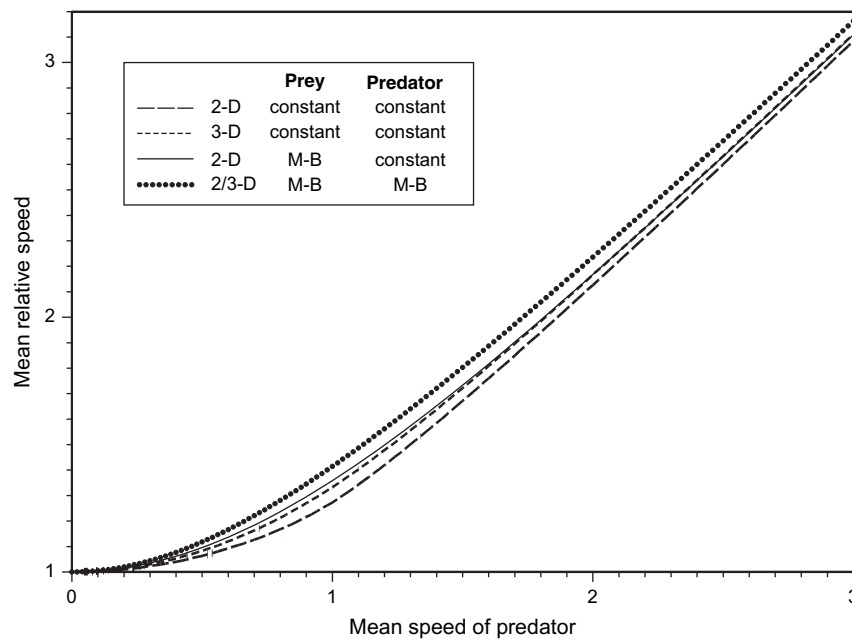

Fig. 4. Mean relative speed of predator and prey as a function of the mean speed of the predator. Encounter rate is directly proportional to mean relative speed. The mean speed of the prey is set to 1. The lines differ in whether movement is in two (2-D) or three (3-D) dimensions, and in whether the prey and predator each have constant speed or whether this varies according to a Maxwell-Boltzmann (M-B) distribution.

carrying fish from its feeding grounds to its nest is seeking to reduce the total number of encounters with kleptoparasites over the course of the journey, not the rate at which they occur. The number of encounters per distance moved by the focal individual is obtained by dividing formulae for rate of encounter by the speed of the focal individual. The number of encounters is then a decreasing function of its speed.

(4) Direction

The formulae also must be amended if the directions of movement are not uniformly distributed, again because this affects the mean relative speed. This might be relevant for animals on a migration or for a population of animals that all tend to avoid moving directly upwind or against a water current. Particular attention has been paid to this issue by researchers estimating densities of seabirds from sightings seen from ships or aircraft, because, for instance, birds commuting between feeding sites and nesting colonies are often predominantly headed in a common direction. Spear *et al.* (1992) proposed recording the heading and speed of each bird seen so as to correct density estimates individually. The estimated density is then the observed encounter rate divided by

$$2D \sum \sqrt{u_i^2 + v_i^2 - u_i v_i \cos \theta_i}, \tag{23}$$

where u_i and v_i are the speeds of observer and the i th bird, and θ_i is the angle between their directions of travel. Spear

et al. (1992) tabulated how the effect of θ on expected encounter rate depends on the ratio of speeds.

As another example, consider a stream of migrating wildebeest within which a male is attempting to intercept receptive females. Imagine that within the migrating column females are moving in parallel, that their speeds follow a two-dimensional Maxwell-Boltzmann distribution, and that the male travels consistently at their mean speed \bar{v} ; then his mean speed relative to females is $0.39 \bar{v}$ if moving with the flow, $1.38 \bar{v}$ if perpendicular to the flow, and $1.89 \bar{v}$ if against the flow. So he encounters more females by moving perpendicular to the flow than moving alternately with and against it (even ignoring the tendency to re-encounter the same females in the latter case). Gerritsen (1980a) applied similar arguments to the three-dimensional world of plankton, for instance predicting that predators should move horizontally in response to vertical migrations or “hop and sink” locomotion of their prey. Anderson, Gurarie & Zabel (2005) developed the ideal gas model in terms of two components to movement, a directed component and a random component, and applied it to model predation of migrating salmon.

IV. TRACKS THAT ARE NOT STRAIGHT

Many of these results break down if individuals do not always travel in straight lines, for instance if they take some sort of random walk. The reason is that bent paths, unlike straight ones, can cross one another more than once. Moreover, random-walking individuals sometimes backtrack,

so one encounter with another individual is relatively likely to be followed by a second encounter with the same individual before they have had a chance to move far apart. The number of encounters among random-walking individuals no longer follows a Poisson distribution, with more chance of many encounters or very few. This invalidates formulae of the form $\exp(-kvpDt)$ for the probability of encountering no items [e.g. as applied when a single encounter suffices to remove a prey item or gamete from the population: Section III(2)]. Nor do the intervals between encounters remain exponentially distributed.

Perhaps surprisingly, expected encounter rates are identical whether or not individuals move in straight lines. However, for random-walking individuals many encounters are recontacts between the same individuals, separated by only brief periods apart. Observers might overlook brief periods apart and thus underestimate encounter rate. For instance, Holenweg *et al.* (1996) introduced a bias into their test of the ideal gas model by explicitly ignoring any change of association status lasting less than 30 min.

Often of more concern than the number of encounters is the number of different individuals encountered. Fewer individuals will be encountered if paths are not straight, but we know of no analytic formulae to make quantitative predictions. However, so long as individuals are moving independently, the number of different individuals encountered will follow a Poisson distribution. Also, doubling the density of individuals still doubles the expected number of different individuals encountered.

It may help to explain these results geometrically. When deriving the formula for encounter rate, we envisaged a strip swept out around the trajectory of an individual relative to the focal individual (Fig. 1); the area of the strip gave the probability of a randomly placed strip covering the focal individual and thus of an encounter. Changes in direction of the trajectory do not affect the area of the strip if areas in which the strip overlaps itself are counted twice (hence the number of encounters is still as predicted by the gas model). But one must count areas of overlap only once to calculate the probability of two individuals ever encountering each other. If individuals move with a regularly turning trajectory (e.g. the sinusoidal movement of fish or the spiral trajectory of sperm: Rosenthal & Hempel, 1970; Farley, 2002) it may be feasible to calculate this area or volume analytically, at least if the items encountered are stationary [see Section V(6)]. Otherwise we must turn to simulation.

(1) Monte-Carlo simulations

Almost fifty years ago, Skellam (1958, p. 398) noted, “Whereas the expected number of encounters does not appear to depend on the shapes of the paths, the variance of the number of encounters does...in order to provide concrete support for the theoretical formulae given earlier and the conjectures outlined above...[one approach is] to set up laboratory experiments on Monte Carlo lines”. Skellam then proceeded to simulate animal movements by moving coloured pins on a triangular lattice on graph paper. Being in a position to set up “experiments on Monte

Carlo lines” with enormously more power than Skellam, we have written a computer simulation to quantify the consequences of animal paths deviating from straight lines.

In these simulations we consider the track of each individual as a series of short straight-line steps of constant duration. This is a flexible and widely used approach to model meandering tracks, and simplifies the calculation of whether two individuals come within range. Since we count only encounters involving one focal individual, and since each simulation run covers a finite time, we need consider only those individuals that would have time to meet the focal individual if they headed straight towards each other at the specified maximum speed. Such individuals lie within a circular arena centred on the focal individual; as the simulation progresses, this circle gets smaller and many individuals become safe to ignore. The initial number of individuals in the arena is generated from a Poisson distribution with mean given by density \times arena area. Their starting positions and directions are randomly allocated assuming uniform distributions.

(2) Correlated random walks

A correlated random walk (successive steps have similar directions) fits most real animal trajectories better than an uncorrelated random walk (e.g. Bergman, Schaefer & Lutich, 2000); one can imagine many reasons why animals tend to avoid backtracking. Unsurprisingly, as the correlation in direction between steps increases, the encounter rate more closely matches predictions based on straight-line trajectories.

To quantify this effect, we modelled the change in direction each step as fitting a von Mises distribution, which is roughly the equivalent of a Normal distribution for angular data (Fisher, 1993). The parameter κ alters the dispersion of turning angle about a mean change of direction of 0, but in Fig. 5 we measure this dispersion in more intuitive terms as the percentage of times the direction changes by less than 90° (“50% steps forward” represents an uncorrelated random walk and “100% steps forward” a straight line). Fig. 5A and B show that as individuals follow more convoluted paths the distribution of the number of encounters changes from a Poisson distribution to one with the same mean but a greater variance. Fig. 5C shows the accompanying decrease in the number of different individuals encountered. Although the broad patterns shown in Fig. 5 are consistent, it is apparent that turning angle distribution, detection distance, step length and step number all have interacting non-linear effects, so quantitative predictions are possible only using simulations.

(3) Rebounds

So far we have assumed that individuals move independently of each other. Another possibility is that when they contact they “rebound” so as to avoid each other. For simplicity, and to utilize results from physics, our assumption here is that the separation distance that counts as an encounter is the same as the distance at which rebounds occur.

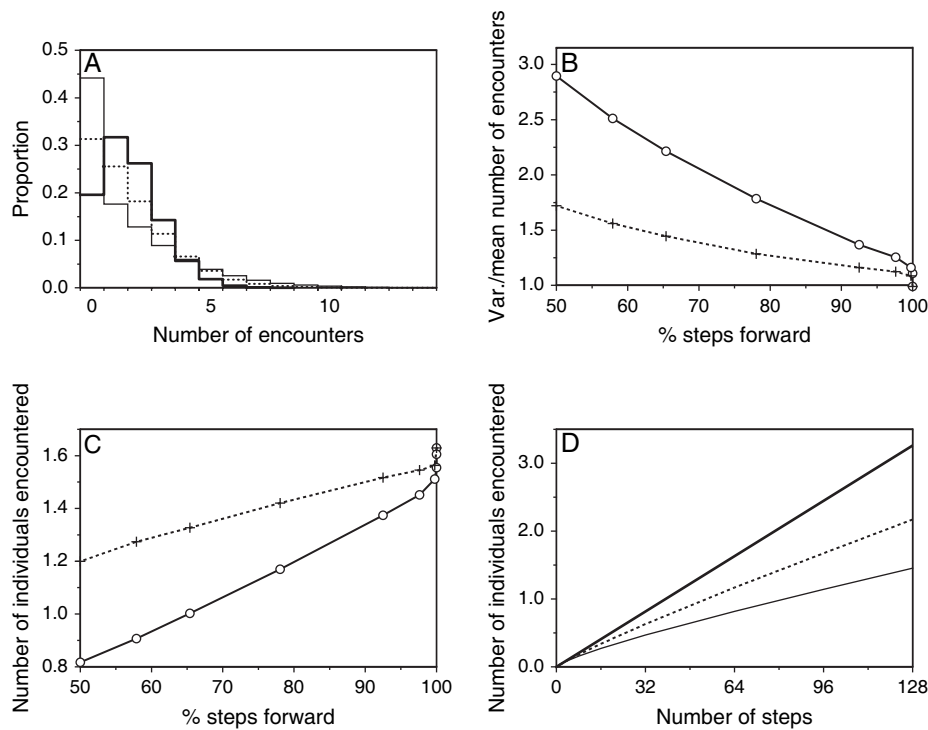

Fig. 5. Deviations from the ideal gas model with a correlated random walk. As a baseline, each simulation consists of 64 straight-line steps, each of 100 m, all individuals move at the same constant speed, detection distance $D = 100$ m, density $\rho = 1 \text{ km}^{-2}$. Turning angle follows a von Mises distribution with dispersion parameter κ ; we transform κ to the percentage of times that the direction changes by less than 90° (“% steps forward”): $\kappa = 0 \Leftrightarrow 50\%$ forward (uncorrelated random walk), $\kappa = 1 \Leftrightarrow 78\%$ forward, $\kappa = \infty \Leftrightarrow 100\%$ forward (gas model assumption). (A) Distribution of number of encounters: thick line = gas model, broken line $\kappa = 1$, thin line $\kappa = 0$. (B) Ratio of variance to mean number of encounters, as a function of κ ; solid line = baseline parameters, dashed line $D = 25$ m and $\rho = 4 \text{ km}^{-2}$. (C) Number of different individuals encountered as a function of κ ; parameters as in B. (D) Number of different individuals encountered as a function of number of steps; other parameters as in A. Each point is based on $\geq 10^5$ simulations.

After a collision, individuals are moving in different directions and cannot contact each other again without rebounding off further individuals, so one might suppose that the ideal gas model would continue to fit well. In fact, when rebounds occur the ideal gas model underestimates encounter rate (Fig. 6). Physicists modelling dense gases have concentrated on two effects (Chapman & Cowling, 1952, p. 274). One is that each particle excludes others from its immediate surroundings, which has an effect of decreasing the area available for movement and thus increasing effective density. The other effect is that when two particles lie close together each shields the other from contact with a third particle; later models have considered clusters of more than two particles screening each other. In two dimensions, based on modelling clusters of ≤ 4 individuals, the predicted rate of encounter $8\rho Dv/\pi$ must be multiplied by a polynomial function of ρD^2 :

$$1 + 0.7820\rho D^2(\pi/2)(1 + 0.5322\rho D^2(\pi/2)(1 + 0.3336\rho D^2\pi/2)) \quad (24)$$

[see van Rensburg (1993) for higher-order “virial coefficients” and those for three as well as two dimensions].

Even formulae based on this approach still underestimate encounter rates at very high densities. At the extreme, individuals are packed in a crystalline fashion; the only movement possible is a slight jostling back and forth from one neighbour to the other; as density tends towards $2/(\sqrt{3}D^2)$ the collision rate tends to infinity. We produced estimates of encounter rate at high densities using a refined version of our Monte Carlo simulation in which individuals encountering each other immediately head directly away, but otherwise move in straight lines at constant speed [Fig. 6A; cf. the simulation by Luding (2001) in which speeds were Maxwell-Boltzmann distributed and collisions preserved momentum and energy].

Fortunately, biological situations to which the ideal gas model has been applied are rarely so extreme. Suppose that an encounter occurs when individuals are 100 m apart; then it requires a density as high as 7.6 per km^2 for the number of encounters to exceed gas-model predictions by 10%. But clearly the ideal gas model would be inadequate at the densities of ants in a nest, for instance. For example Gordon *et al.* (1993) studied encounter rates in ants kept at densities up to 0.72 per cm^2 . Even were detection distance as small as 0.6 cm (the length of these ants), the expected number of encounters is 40% more than predicted by the ideal gas model.

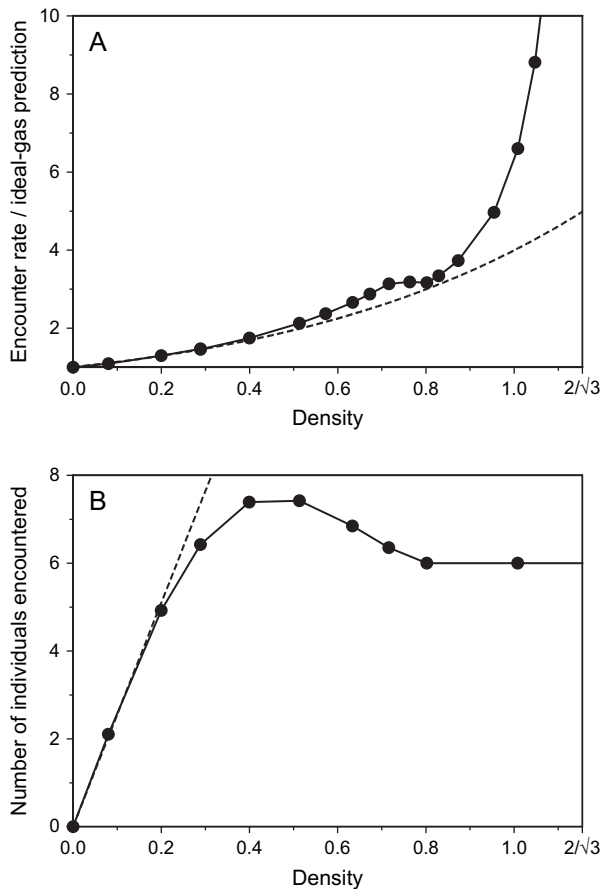

Fig. 6. Deviations from the ideal gas model when individuals rebound. Density is measured as individuals per unit² and rebounds occur at a separation of 1 unit between centres. Speeds are constant, with individuals heading directly away after contact. At high densities, disks are initially arranged on a triangular lattice on a toroidal surface; simulation continues until collision rate has reached equilibrium. (A) Number of encounters relative to ideal gas model. Dashed line shows the analytically derived correction factor based on virial coefficients up to order 8 (van Rensburg, 1993). Solid line shows the factor by which collision rate in our simulations exceeded the gas-model prediction. The inflection is associated with the “phase change” to a crystalline form in which individuals are unable to slip past one another (see Luding, 2001). Each point is based on 20000–100000 simulations of 100 disks. (B) Number of different individuals encountered in a travel distance of 10 units. Solid line is from our simulations, dashed line is that predicted by the gas model assuming straight-line trajectories. Each point is based on 10000 simulations of a minimum of 100 disks.

However, ant encounters are often of interest because they enable the transfer of information (Adler & Gordon, 1992). In this context what matters are contacts between individuals that have not recently met one another. At high densities our simulations demonstrate that the rate of novel contacts is decreased by each individual becoming “boxed in” by neighbours (Fig. 6B).

(4) Other forms of non-independence

In nature individuals are often aggregated and even simple predators consequently adjust their foraging paths to tend to remain within prey aggregations (area-restricted search). Encounters with prey may stimulate adjustments of turning angles, speed or both. This kind of non-independence invalidates the ideal gas model; for instance we no longer expect a linear relationship between density and encounter rate (e.g. Travis & Palmer, 2005). The ideal gas model is most useful in such situations as a null model of independent movement against which to compare the improvements in encounter rate achieved by more sophisticated behaviours. The tendency for seabirds either to follow ships or to turn away from them at distances greater than observers can identify them also invalidates the ideal gas model, which creates problems in calculating densities from ship-based counts.

V. CORRECTIONS OF SOME ERRORS IN THE LITERATURE

The papers that have made the errors considered below have often also identified novel situations to which the ideal gas model can be applied. It is thus worthwhile not only to point out the mistakes, and to quantify how much they matter, but to show how they might be corrected.

(1) Encounter duration

Waser (1984, 1987) calculated the expected duration of an encounter under the assumptions of the ideal gas model. This provided a null hypothesis against which to compare observed durations, to test whether avoidance or other interaction occurred. He calculated the probability distribution of the relative speeds between random pairs of particles and then integrated the product of probability and the reciprocal of relative speed. What Waser neglected was that encounters occur more often when relative speeds are high. As we saw in Section II(2), the correct calculation is to divide $\rho\pi D^2$ by encounter rate. In the case of Maxwell-Boltzmann distributions of speeds, the correct formula is

$$\pi D / (2\sqrt{u^2 + \bar{v}^2}). \quad (25)$$

Waser’s formula overestimates this by a factor of $\pi/2 \sim 1.57$, which neatly explains why Waser’s (1984) predictions exceeded his observations by about this factor. Other papers involving this error are Cords (1987), Mitani *et al.* (1991), Holenweg *et al.* (1996) and van Schaik (1999), although the error is insufficient to have changed their qualitative conclusions. Whitesides (1989) also followed Waser (1984) in using the wrong formula, but relied more on the results of a simulation which were immune to the error (he observed, but did not follow up, the discrepancy between the two methods of prediction).

Calculations of the proportion of time spent in contact with others that rely on multiplying encounter frequency by Waser’s formula for encounter duration are also overestimates

by the same factor of 1.57 (Waser, 1987; Whitesides, 1989; Mitani *et al.*, 1991; Holenweg *et al.*, 1996).

(2) *D* for spread-out groups

Waser (1976) realized that the ideal gas model might usefully be extended to encounters between social groups, but unfortunately introduced an error into the literature. If the diameter of each group is *s*, and the maximum detection distance between individuals is *d*, peripheral members of the groups may detect each other when the group centres are *d + s* apart; this corresponds to *D* in our equations (Fig. 7). However, instead of the $2(d + s)$ that should have appeared in his encounter-rate equation, Waser (1976) wrote $2d + s$. His later papers applying the same technique (Waser, 1982, 1984, 1987) did not repeat the error, but it has propagated in several doctoral theses (Bennett, 1984; Hill, 1991; Ham, 1994; see also Schülke & Kappeler, 2003). Also, a review paper by Dunbar (2002) erroneously implies that *D* should be taken as the distance between the edges of the groups (*d*), ignoring group diameter.

Barrett & Lowen (1998) were the first to point out that the $2d + s$ term used by Waser (1976) was wrong. Unfortunately they corrected the encounter-rate formula to $4\rho\nu(s + d)/\pi$; this needs to be multiplied by a factor of 2.

(3) Partial overlap of home ranges

Barrett & Lowen (1998), following van Schaik, van Amerongen & Mouton (1985), noted that the ideal gas approach might introduce errors when home range overlap between neighbouring individuals (or, in this case, primate social groups) is not complete. They therefore introduced a further factor *x* into the encounter-rate formula, which represents the proportion of the group's time spent in the part of their range shared with other groups. They made the additional assumption that the group spent half as much time in the shared part as expected on the basis of its area,

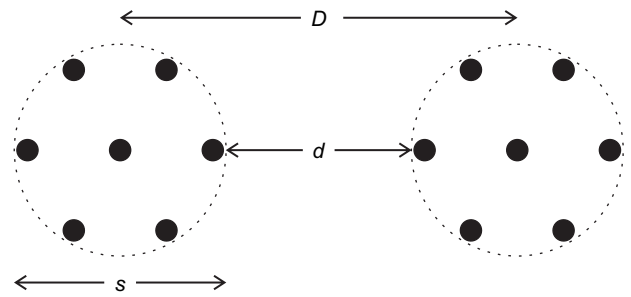

Fig. 7. If each individual can detect another *d* away, and they form groups of diameter *s*, then groups can detect each other when their centres are *d + s* apart and so this should replace *D* in the standard formulae.

because resources there were depleted by their neighbours. However, this and similar analyses (e.g. Kinnaird & O'Brien, 2000) are subject to several pitfalls.

There is a typographical error in the equation Barrett & Lowen (1998) printed to make their intended adjustment. Their equation A7 should read $x = (c/2)/(b + c/2)$ which indeed yields the *x* value that they report. More fundamental a mistake is that multiplying by *x* fails to take into account that the neighbours, like the focal group, will spend only some of their time in the shared area. Kinnaird & O'Brien (2000), in a similar analysis, apparently realised that it was the probability of groups being simultaneously in the shared area that mattered, but did not allow for the increased density when this occurs.

For simplicity suppose that suitable habitat is distributed along a narrow strip 1 unit wide and that a large number *N* of groups are spaced evenly along the strip (Fig. 8A). If the strip is *N* units long, the density is one group per unit area, but we specify that each group occupies a range of length and area *h*, resulting in each group sharing a strip of width and area *h - 1* with each neighbour. If density is not unity, the results derived below still hold if *h* is defined as area of

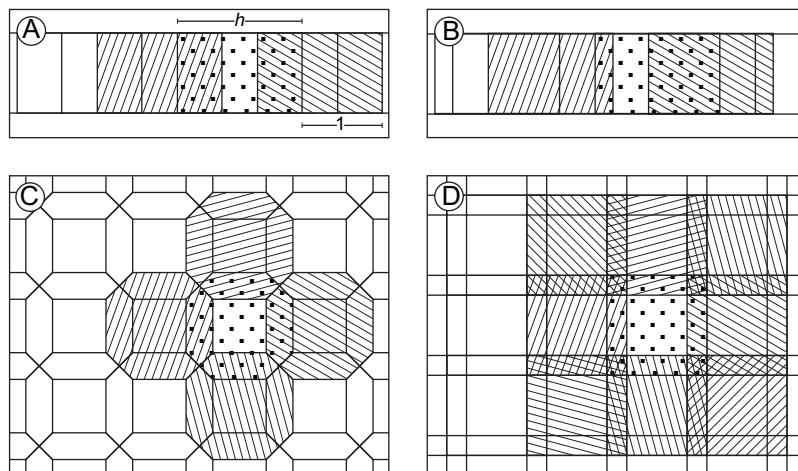

Fig. 8. Configurations of overlapping territories in which home range \times density = $h = 1.56$. Home ranges overlapping the stippled home range are shown hatched. For configurations A, B and C, the correction factor assuming equal usage within a home range = $2(h - 1)/h^2 = 0.46$. For configuration D, the corresponding correction factor = $4(\sqrt{h} - 1)(2\sqrt{h} - 1)/h^2 = 0.61$.

home range \times density (i.e. as actual home range area divided by the area if home ranges were reduced to cover the region without overlapping).

The proportion of time that each group spends in each of its shared areas is $(h - 1)/h$ if it visits all parts of its range equally often. The probability that both the focal group and the neighbour are in their shared area is $(h - 1)^2/h^2$. When that happens the density of the neighbour within the shared area is one per $h - 1$ of area, $= 1/(h - 1)$. Note that to calculate encounter rate of a focal group requires local density to be calculated ignoring the focal group itself (cf. Jolly *et al.*, 1993). So the predicted rate of encounter between two particular neighbours $= [(h - 1)^2/h^2] \times 1/(h - 1) = (h - 1)/h^2$ times that given by the usual encounter-rate formula. (Unfortunately, even this correction factor is an underestimate, especially with large D , because the centre of one group can be just outside the area of shared use, but still lie within distance D of a neighbouring group whose centre is within it.) Because each group has neighbours on either side, the rate must be doubled to give a group's overall rate of encounter:

$$2(h - 1)/h^2. \quad (26)$$

This lies between 0 and 0.5 if no area is to be shared by more than two groups. If we instead assume that groups visit shared resources half as frequently as resources in their unshared home range centre, the correction factor becomes

$$(h - 1)/2 \quad (27)$$

[whereas Barrett & Lowen's (1998) correction factor of x corresponds to $h - 1$; it happens that this error cancels out their earlier error pointed out in Section V(2)].

These formulae still hold if the area of overlap with each neighbour varies and regardless of the number of neighbours with which each group shares its home range, but only so long as every group still has an equal sized home range, with the same proportion of it shared, and there are no areas shared by three or more individuals (Fig. 8B, C); these seem reasonable rough approximations for many systems. Fig. 8D illustrates a configuration in which some areas are shared by four groups; the correction factor, assuming that each group utilises all parts of its range equally, is then increased to $4(\sqrt{h - 1})(2\sqrt{h - 1})/h^2$, which gets as high as 0.76 when $h = 2$.

Thus when home ranges do not overlap completely, expected rates of encounter will be decreased by an amount that depends not only on how much home ranges overlap, and on relative usage of those areas of overlap, but also on some aspects of overlap configuration. Where the geometry of home range overlap is more complex, the investigator will need information on the ranges of neighbours as well as that of the focal group, and accurate null predictions will require simulation.

(4) Infanticide rate

The issue of how to correct for overlapping home ranges also arises in a model of infanticide in the great apes

(Harcourt & Greenberg, 2001), but it is exacerbated by further complications that we now discuss. To predict the probability of infanticide, Harcourt & Greenberg (2001) used the ideal gas model to calculate both the proportion of males that would not meet a female when she was in oestrus, and the proportion that would meet her later when she was nursing (only males that do not mate with a female but do encounter her while nursing are assumed to kill infants). They took the product of these proportions to calculate the probability of an infanticide: their formula is of the form $\exp(-2\omega D\rho t_c) \times (1 - \exp(-2\omega D\rho t_n))$, where ω is the mean relative speed, D is the distance at which a male would detect a female, ρ is the male density, and t_c and t_n the periods of oestrus and nursing respectively (here we have corrected the omission of a factor 2 in the encounter-rate formula).

Unfortunately, their formula becomes inappropriate when more than a single male is present in the female's range. To understand why, consider the situation when the time spent nursing is very long (as with the great apes), so that $\exp(-2\omega D\rho t_n) \sim 0$ and Harcourt & Greenberg's (2001) formula reduces to $\exp(-2\omega D\rho t_c)$. This is the probability of no encounters with any of the males during oestrus. But all it takes for an infanticide is for one male not to have met the female: it is unnecessary for all not to have met her. The greatest danger are males who rarely encounter the female, those whose home ranges overlap the female's range only a little. It should now be apparent why it becomes necessary to consider range overlaps with each male individually. The probability that each male commits infanticide can be calculated as Harcourt & Greenberg (2001) did, but then one must calculate the product of the probabilities that each male does *not* do so to give the overall probability of no infanticide. The correct formula for the probability of infanticide is thus of the form

$$1 - \prod_{i=1}^M [1 - \exp(-2\omega D\rho_i t_c) \times (1 - \exp(-2\omega D\rho_i t_n))]. \quad (28)$$

Here M is the number of males with ranges overlapping a female's home range and is usually greater than obtained by multiplying male density by the area of female home range [the apparent basis of Harcourt & Greenberg's (2001) calculation]. Crucially, now ρ_i is not male density ρ , but a quantity reflecting pairwise male-female range overlap as well as density.

To illustrate this, we use Harcourt & Greenberg's (2001) parameters for the Virunga gorilla (*Gorilla gorilla*), under the fictional supposition that females were solitary. Home range $= 7.5 \text{ km}^2$ and adult male density $= 0.25 \text{ km}^{-2}$, so $h = 7.5 \times 0.25 = 1.875$. Let us suppose that the topology of male home ranges is like Fig. 8C, and that the female's home range exactly matches the male home range marked with spots. For that home range $\rho_i = 1/7.5 \text{ km}^{-2}$. For each of the four other overlapping male home ranges $\rho_i = \rho(h - 1)/(2h^2) = 0.031 \text{ km}^{-2}$ [derived similarly to formulae in Section V(3)]. The probability of infanticide is then $1 - [1 - \exp(-2 \times 0.71 \times 0.5 \times 0.133 \times 6.25)] \times [1 - \exp(-2 \times 0.71 \times 0.5 \times 0.031 \times 6.25)]^4 = 1 - 0.45 \times 0.13^4 = 0.9999$. This is much higher than Harcourt & Greenberg's (2001) value. But note that the value would differ were

the female home range to be superimposed differently on the male home ranges or if the males had a different configuration of home ranges; much more information has to be specified for a reliable prediction, particularly about males that enter the female's home range only occasionally. One complication not covered by the formula is that, if during the few days of her oestrous the female is in the corner of her home range where she is liable to encounter one male, she is unlikely to wander into all the other corners where she could meet the other males whose home ranges overlap hers only slightly. This, as well as the typical tendency to spend disproportionately less time in non-exclusive peripheral parts of the range, will tend to increase further the probability of infanticide.

(5) Mating benefits of an increased home range

There is another problem with Harcourt & Greenberg's (2001) study, and indeed with our corrected formula. It arises also in several papers using the ideal gas model to examine whether males, rather than being monogamous, would profit from defending an enlarged home range containing the home ranges of several females (van Schaik & Dunbar, 1990; Dunbar, 1995, 2000). What is critical in these latter papers is the number of different fertile females that a polygamous male would encounter. This was estimated as $n(1 - e^{-m})$, where n is the number of females in the male's territory and m is the expected number of encounters with each female within three fertile periods, as calculated from the ideal gas model. However, with non-straight trajectories the number of encounters is not Poisson distributed; therefore e^{-m} (from the Poisson distribution) accurately estimates how often no encounters occur only if m equals the mean number of different individuals encountered, not the mean number of encounters. The predicted advantage in being polygamous is potentially much diminished.

To gauge the magnitude of the error, we consider a correlated random walk consisting of straight-line steps each lasting 30 min and turning angles described by a von Mises distribution with $\kappa = 0.69$, which is based on observed movements of grey-cheeked mangabey groups analysed in Section VII. We combine this with one set of van Schaik & Dunbar's (1990) figures for the gibbon *Hylobates lar*: speed = 0.108 km h^{-1} , detection distance = 25 m, density of a particular female within the enlarged male territory = 0.75 km^{-2} , and a female is fertile for three consecutive days (= 72 steps of our random walk). Simulations predict that the male would encounter a mean of 1.00 different females, compared with 1.52 total encounters, so the probability of not meeting a particular female in his territory is $(1 - e^{-1.00}) = 0.63$. If, following van Schaik & Dunbar (1990), we allow three cycles for a successful copulation, the probability of fertilizing a particular female is $1 - 0.63^3 = 0.75$. If a mean of 4.5 females remained within a male's territory, the expected number of females that he fertilizes is $0.75 \times 4.5 = 3.3$ (assuming that, if females are territorial, they do not all become fertile at the same time, so that encountering one fertile female does not mean that the male is less likely to

encounter another). The original prediction was 4.5 (all females mated); the corrected estimate remains greater than the 1 expected under monogamy, but remember that we used an estimate for the convolution of the path based on a quite different species.

Note also that van Schaik & Dunbar (1990), as well as Dunbar (1988, p. 309; 1995; 2000), apply the version of the ideal gas model appropriate for interactions between moving and stationary individuals to situations where all individuals are moving, thus underestimating encounter rate by a factor of at least $4/\pi = 1.27$.

(6) Spiral trajectories of sperm

Errors in application of the ideal gas model are not confined to primatology; here is an example from work on fertilization kinetics. Usually sperm are so small relative to the egg that the critical distance D is set simply as the radius of the egg r_e . The term πD^2 term in the three-dimensional encounter-rate formula is thus πr_e^2 , which equals the cross-sectional area of the egg. However, Farley (2002) pointed out that sperm trajectories are typically helical, so that it is reasonable to consider the sperm as having a diameter that of the outside of the helix (with a correspondingly slower forward speed). In that case D should be set as the radius of the egg plus the radius of the helix (r_s), and πD^2 becomes $\pi(r_e + r_s)^2$. Instead Farley used $\pi(r_e^2 + r_s^2)$, believing mistakenly that adding the cross-sectional areas of the egg and the helix was the appropriate procedure; his predictions of initial encounter rate should be 1.5–1.8 higher.

The corrected predictions turn out to exceed observed encounter rates. One potential reason is that the revised formula calculates the volume of a cylinder of radius $r_e + r_s$, whereas the real probability of encounter is given by the volume of a helix fitting exactly within this cylinder but not fully filling it; the helix is constructed by dragging a sphere of radius r_e along the sperm's trajectory relative to the egg. Because the egg is stationary, this relative trajectory is a regular helix and thus the volume is feasible to calculate. Sperm stop moving after encountering an egg, so the relevant volume should be calculated by counting volumes of overlap between consecutive turns of the helix once only. With the parameter values of this example, the volume turns out to be exceedingly close to that of the enclosing cylinder. So the revised version of Farley's (2002) calculation is an excellent approximation and other explanations must be sought for the disagreement with experiment. If we had assumed that the sperm's track was straight instead of helical, the volume, and the predicted rate of encounter, would have been a factor of 3.3–4.7 too high. We recommend trying an analogous treatment of the wide sinusoidal sweeping movements of the heads of some predatory fish (Rosenthal & Hempel, 1970).

(7) Predation in the plankton

An example from this latter field concerns rates at which jellyfish (*Aurelia aurita*) capture herring larvae (*Clupea harengus*). To replace the assumption that the herring are points or spheres, Bailey & Batty (1983) supposed that they

were lines of length L . The detection distance between the centre of the jellyfish (taken as a sphere of radius r_j) and the centre of the herring then depends on the orientation of the herring relative to its direction of movement towards the jellyfish. Bailey & Batty (1983) used an incorrect formula for this, but more fundamentally they overlooked that—because the absolute velocity of the herring is oriented along its body, and the absolute velocity affects the orientation of the relative velocity—the herring tends to be oriented close to the direction of the relative velocity. The correct formula for encounter rate is

$$\rho \int_0^\pi \left(\sqrt{u^2 + v^2 - 2uv \cos \theta} \pi r_j^2 + r_j L v \sin \theta \right) \sin \theta \, d\theta / 2, \tag{29}$$

where θ is the angle between the absolute velocities of herring and jellyfish, and u and v are their respective speeds (see Fig. 9 for derivation). Over the size range of jellyfish considered, Bailey & Batty’s (1983) formula overestimates the correct predictions of encounter rate by factors of 1.17–1.55; the corrected predictions worsen the fit to their observed rates of predation in the laboratory. Unfortunately

the incorrect formula has been used by a number of other authors (e.g. Cowan & Houde, 1992; Letcher *et al.*, 1996). Incidentally, it is easy to make the model a little more realistic by replacing the line with a cylinder of radius r_h and length L capped with hemispheres (so total length = $L + 2r_h$). Then simply replace r_j in (29) with $r_j + r_h$.

Several papers copying the erroneous formula use it to assess how predation affects the size-distribution of fish larvae. Paradis, Pépin & Pepin (1999) and Paradis & Pepin (2001) considered a cohort of larvae that as they grow are preyed by predators of a range of sizes. For each predator species they apparently used its modal size to calculate the probability of N encounters with a prey of each size. They then randomly selected one predator size from a truncated normal distribution (\pm c. 2S.D.) about this mode, and the ratio of prey to predator sizes was used to calculate the probability that each encounter led to predation. The potential problem is with the use of the mean predator size to calculate the number of encounters. Predators of above-average size are disproportionately likely to encounter a prey item, and their encounter rate is affected by prey size to a different degree. We assessed how important this was by using the parameter values of Paradis *et al.* (1999) but considering predation only by crustaceans (115 per m^3). Our recalculations dividing the predator population into

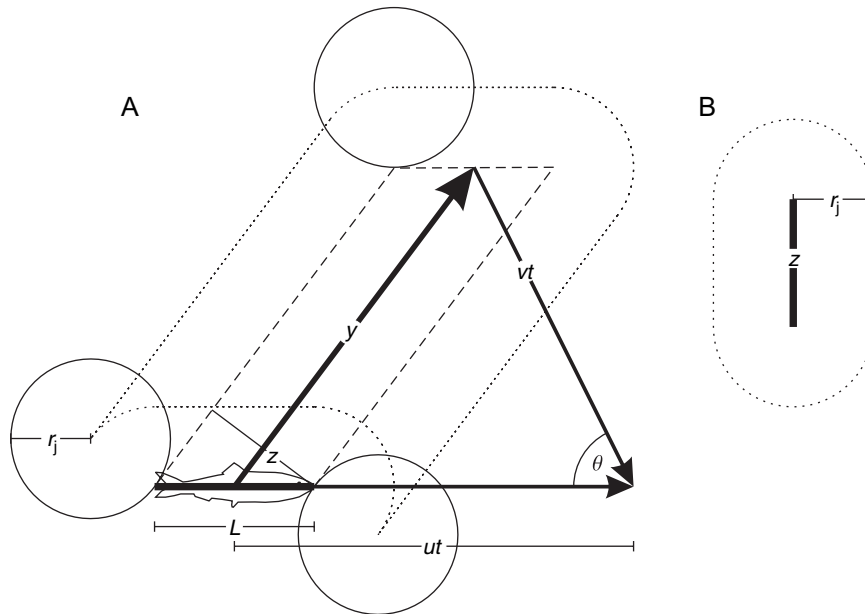

Fig. 9. Encounters between jellyfish moving at speed v at an angle θ to herring moving at speed u . We assume that the herring has length L but is infinitely thin. A shows this situation in the plane common to both movement vectors. The trajectory of the herring relative to the jellyfish is shown by the thick vector and has length $y = t\sqrt{u^2 + v^2 + uv \cos \theta}$. The parallelogram outlined by a dashed line shows those starting positions of an infinitely small jellyfish that would result in a new encounter within time t . The width of this parallelogram perpendicular to the relative trajectory is $z = (Lv \sin \theta)/y$. However, instead the jellyfish are considered to be spheres with radius r_j , and the three circles show examples of positions that result in one part of the jellyfish just touching the herring. The dotted outline marks the envelope of positions of the jellyfish centre that result in new encounters. B shows the cross section of this space cut perpendicular to the relative trajectory. The area of the cross section is $\pi r_j^2 + r_j z$. This must be multiplied by the length of the relative trajectory of the herring (y) to give the volume of the space: $y(\pi r_j^2 + r_j z) = y\pi r_j^2 + r_j L v \sin \theta$. Calculating the expected number of encounters then involves integrating this over θ (see Fig. 2).

multiple size classes increase mortality over the first day from 2.8% to 5.0%, but the difference diminishes as the prey grow larger than their predators, so mortality after 30 days increases only from 60% to 75%. (We failed to resolve the discrepancy between the 60% figure and the considerably lower mortality levels calculated by Paradis *et al.*, 1999) Reassuringly, the recalculations turn out scarcely to alter the size distribution of survivors. Repeating the recalculations using our corrected version of Bailey & Batty's (1983) formula decreases mortality to 48% (3.8% on the first day), and results in a larger mean size of survivors, but by only a third of a daily growth increment.

(8) Estimating seabird densities from ship- and aircraft-based counts

Gaston & Smith (1984) and Gaston, Collins & Diamond (1987) sought to quantify the error in estimates of seabird density derived from counts of individuals flying within a prespecified distance of a ship or aircraft. In particular they examined the effect of the direction in which birds were flying relative to the path of the observer. The effect has two components, both of which Gaston & Smith (1984) and Gaston *et al.* (1987) miscalculated. One component is the increased relative speed when observer and birds are travelling in opposite directions [see Section III(4)]. An additional effect occurs if the area monitored is not circular. Gaston & Smith (1984) considered a rectangular area aligned with the observer's absolute direction of movement (Fig. 10); let the width be $2D$ and the length a . Consider the bird as the focal individual and the ship as laying down a strip along its trajectory relative to the focal individual. The width of this strip depends on the direction between the relative trajectory and the absolute trajectory, which depends on the angle between the absolute trajectories of ship and bird (θ), and on their speeds (u and v respectively):

$$\frac{\sqrt{(4D^2 + a^2)}\sin(\tan^{-1}(2D/a) + |\tan^{-1}((v \sin \theta)/(u - v \cos \theta))|)}{(u - v \cos \theta)} \tag{30}$$

This must be multiplied by the relative speed to generate the expected rate of encounter divided by bird density.

Different shapes of area monitored require different calculations. The algebra for the case of an ellipse aligned along the direction of movement turns out particularly neatly: the rate of encounter is

$$2\rho\sqrt{(av \sin \theta)^2 + b^2(u - v \cos \theta)^2} \tag{31}$$

(where u , v and θ are as above, ρ is target density, the ellipse has length $2a$ along the direction of movement and width $2b$ perpendicular to it). An ellipse seems an appropriate way to model the greater sensitivity of many organisms in a forward direction (the algebra is unchanged if the observer is positioned behind the ellipse centre). However, if the field of

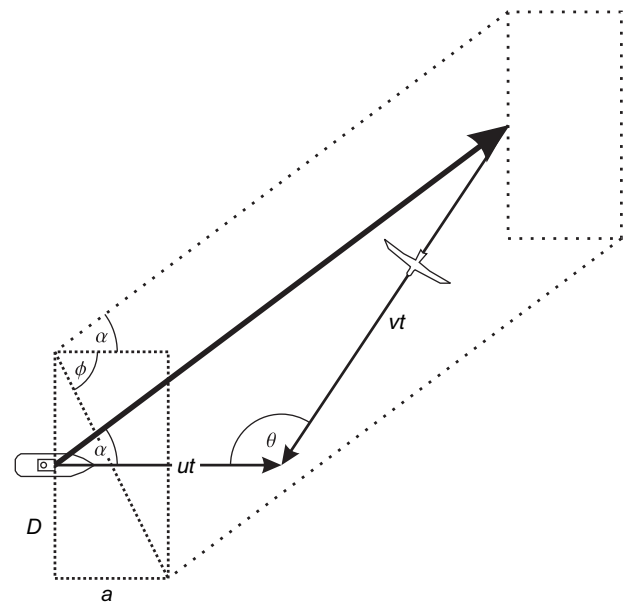

Fig. 10. Calculation of the number of birds entering a rectangular area ($2D \times a$) in front of a ship moving with speed u . Consider the ship's motion relative to a bird flying with speed v at an angle of θ to the course of the ship. Relative to the bird the ship moves a distance $t\sqrt{u^2 + v^2 + uv \cos \theta}$ in time t (shown as thick vector in the figure). The movement of the rectangular area along this relative trajectory covers a strip with sides of this length and with width $\sqrt{(2D)^2 + a^2} \sin(\phi + |\alpha|)$, where $\phi = \tan^{-1}(2D/a)$ and $\alpha = \tan^{-1}(v \sin \theta)/(u - v \cos \theta)$. The area of the strip is the product of this width and length, and the expected number of encounters is this area times bird density (integrating over θ if birds are not all travelling in the same direction).

sensitivity is not circular the rate of encounter increases whenever the observer changes direction (or even turns its head), so the method may not be readily applicable. See Skellam (1958) for a discussion of this point.

One relevant situation largely avoiding this rotation issue is of a primatologist or ornithologist conducting a census along a path through thick vegetation. The area effectively monitored may then often be keyhole shaped: a long narrow rectangular area of clear visibility along the path in front, combined with a circular area centred on the observer. One approximation to modelling this would be to calculate the number of encounters at the periphery of the circular area (by the standard formula) and then to add the number of encounters expected for the rectangular area sticking out beyond this circle (calculated by the formula developed in Fig. 10). Animals first crossing the rectangular area and then the circular one would be counted twice by such a calculation, but they might also often be in the field (except for those that remained in view on the path).

If the path were narrow and the animals small, one might reasonably consider the region monitored as one dimensional, setting D to 0 in the formula derived from Fig. 10.

The expected number of animals crossing the path ahead within a distance a of the observer is then

$$\rho \int_0^\pi avt \sin \theta d\theta / \pi = 2\rho avt / \pi. \quad (32)$$

Note that this is independent of the speed of the observer. The same formula is also applicable to counts of seabirds crossing the bows of a ship within a specified distance in front (assuming a uniform distribution of their directions of flight, and that the ship is not turning).

Another procedure when estimating seabird densities is to count only birds on one side of the ship, so that the area monitored is half a circle. In that case it makes the calculations much simpler to count only birds entering the area across the curved side (i.e. ignoring those entering the semicircle from the other side of the ship); the expected number is then simply half that if one were looking round the full 360° (assuming a uniform distribution of directions, but otherwise the side of the ship monitored could be alternated).

VI. HOW TO TEST THE PREDICTIONS?

In most of the earlier work that tested whether the ideal gas model adequately described animal behaviour, conclusions were based only on whether the predicted and observed number of contacts seemed to differ substantially. More rigorous statistical tests might be based on three different approaches.

One approach relies on the assumption that the number of encounters is Poisson distributed, which we know not to be exactly true unless the trajectories are straight, but which is a reasonable approximation in particular cases. Non-straight trajectories increase the variance in the number of encounters, so assuming the Poisson distribution will reject the null hypothesis too often. When the predicted number of encounters μ is small, confidence limits are calculated from the usual formula for a Poisson distribution:

$$\text{probability of } \leq i \text{ encounters} = \sum_{j=0}^{j=i} \frac{\mu^j e^{-\mu}}{j!}. \quad (33)$$

When μ is larger it will be necessary to approximate this by a normal distribution with variance μ .

The second approach, originally suggested by Skellam (1958), is to make several independent observations of encounter rate and then make use of the variance in these observations, allowing a t -test to compare the mean of these observations with the prediction. The distribution of the observations can be more skewed than a Poisson distribution (Fig. 5A), but, as a result of the central-limit theorem, the distribution of the mean of m observations should usually be well approximated by a t -distribution. A square-root transformation will tend to improve the approximation, especially when the number of encounters is small.

The advantage of the t -test approach is that we need not know whether the individuals are taking straight or convoluted paths—the predicted number of encounters is unaffected, and the test does not rely on assumptions of a Poisson distribution. Note, however, that the assumption of independent observations is violated if we use consecutive periods of observation on the same animal or use simultaneous observations of neighbouring animals. The latter is a problem with the statistical test of Mitani *et al.* (1991), which treats the encounter rates of each of a group of neighbouring orang-utan with the others as independent, but not with that of Schülke & Kappeler (2003), which is based on encounter rates only within different male-female pairs. Note also that the use of a χ^2 test to compare observed and predicted number of encounters (Jolly *et al.*, 1993; Gursky, 2005) is inappropriate.

Simulation provides a third way to test predictions about encounter rate. We advocate building tailored simulation models based on the movement patterns of the species of interest. The proportion of simulation runs in which the number of encounters is equal to or more extreme than the number observed provides directly a one-tailed p -value, which can be doubled to provide a two-tailed value (Manly, 1997, p. 72). Or the quantiles of the distribution of encounter number may be used as confidence intervals.

A simulation is easier to write and faster to execute if we assume that trajectories are composed of straight-line steps and that the changes in direction occur simultaneously in all individuals. This may affect the best way to gather data: for instance Waser's (1976) recording of the position of mangabey groups every half hour produces data that can be put directly into such a model. By contrast, Barrett & Lowen (1998) recorded time and position whenever the group moved more than 10 m, which gives a more accurate description of the trajectory but is more complicated to incorporate in a simulation.

The simulation will select step lengths and turning angles at random from the observed distributions; there is little computational cost to incorporating any observed correlations between these variables, or any autocorrelation. Such modifications will not alter the mean number of encounters from that predicted by the ideal gas model, but will broaden the confidence limits. Hence, if our first approach of relying on the Poisson distribution already fails to reject the null hypothesis, there would be no need to develop such a simulation. However, at some greater cost in computational time one might incorporate further details of the biology as part of the null hypothesis, and these may affect predicted encounter rate.

Restricted home ranges are one important violation of the assumptions of the ideal gas model. The simple analytic model in Section V(3) showed that the extent of home range overlap affects encounter rate considerably. Two ways to set up home ranges in a simulation are to restrict movements to an area defined by the observed home ranges or to engineer a biased random walk in which the directions of movement are increasingly likely to lead back towards a central point the further away the animals drift. Either could be biologically reasonable, and both could be incorporated in the same model. The choice does matter because it affects

whether peripheral zones of a home range, which are likely places for encounters, are less frequently visited than elsewhere. Other possibilities that could be readily incorporated into a simulation model are a tendency to visit a shared area less frequently because of the greater competition for food there, or a tendency to spend more time patrolling the edge of an exclusive territory.

The more such biological details that are incorporated into a model the more confidence one might have that any disagreement of observations and prediction is due to interactions with other individuals, rather than to other unconsidered complexities of the movement patterns. One might even then incorporate hypothesised responses to nearby individuals to test whether these are sufficient to explain the discrepancies. However, it is unlikely that the information for a full model will be available for anything but a laboratory system. Such factors as difficulty of moving through scrub may dominate an animal's choice of path, yet be hard to incorporate into a model.

One appealing alternative to simulating tracks is to use real tracks made by animals in the same locality. The idea is that animals following two sets of tracks made at different times cannot have responded to each other, and thus the number of fictional encounters between them provides a prediction under the null hypothesis of no interaction. This is a randomization procedure (Manly, 1997). The two sets of tracks might even be from the same animal at different times, an approach taken below in our worked example. The time separation should be sufficient that the animal could have moved anywhere else in its range within that time, and ideally should be long enough to preclude indirect interactions through scent marking or local food depletion. In species in which individuals set up stable territories that largely avoid the territories of others, the procedure cannot exclude these long-term interactions from the null hypothesis, unless the habitat is sufficiently uniform that it would be reasonable to shift tracks in space as well as time. However, it may often be a strength of the approach to be able to test whether unexpectedly more or fewer

encounters occur between particular neighbours given their observed home ranges. This is the approach of Doncaster (1990) who compared the observed separation distances of neighbouring foxes with those generated by taking distances between random points (i.e. times) on their two tracks.

VII. AN EXAMPLE: GREY-CHEEKED MANGABEY INTERGROUP ENCOUNTERS REANALYSED

We have discussed a variety of ways to predict the number of encounters and to test whether the observed number differs statistically from the prediction. Here we illustrate some of these approaches using data on grey-cheeked mangabeys (*Cercocebus albigena*) in Kibale Forest, Uganda (Waser, 1976). The location of the centre of a focal group was recorded every 30 min, typically for 9–12 h each day, for a block of 10 days each month, over a total of 12 months. We use Waser's original estimates of a density of 0.25 groups km⁻², and a group diameter of 90 m. Waser observed four encounters within 200 m, and 11 within 500 m. These encounters, rather than having already started when observations began, all started during the course of the day.

The total period of observation was 1130.5 h, during which time the group moved 133.5 km. The simplest version of the ideal gas model thus predicts $(4/\pi) \times 0.25 \times 133.5 \times 2(0.2 + 0.09) = 24.6$ encounters within 200 m and 50.1 encounters within 500 m (Table 1).

However, the distance moved in each half-hour (i.e. speed) varied considerably. If we assume a Maxwell-Boltzmann distribution of speeds, the predictions increase by a factor of 1.11. But the Maxwell-Boltzmann distribution is not a particularly close fit to the observed speed distribution. Instead a $x^{0.3}$ transformation produces a reasonable fit to a normal distribution. If we truncate this at the observed minimum and maximum and integrate numerically, the mean relative speed increases further from

Table 1. Observed and predicted numbers of encounters for a mangabey group followed for 2261 half-hour intervals in Kibale Forest, Uganda. We were unable to retrieve the data from 74 of the original 2474 data points used by Waser (1976) owing to loss or degradation of the IBM cards. The models are explained in the text. The last column indicates the basis of the confidence limits: *t* = *t*-distribution, P = Poisson distribution, s = simulation

	Encounters < 200 m		Encounters < 500 m		
	mean	95% CL	mean	95% CL	
Observations	4		11	$2 \leq x \leq 18$	<i>t</i>
Predictions of Waser (1976)	22.5		50.0		
Gas model: constant speed	24.6		50.1		
Gas model: Maxwell-Boltzmann speeds	27.4		55.7		
Gas model: observed speed distribution	29.7	$21 \leq x \leq 38$	60.5	$48 \leq x \leq 73$	P
Ditto, + range overlap	13.5		27.5		
Ditto, + observed usage of overlap	12.5		25.5		
Correlated random walk simulation	29.7	$8 \leq x \leq 59$	60.6	$27 \leq x \leq 103$	s
Ditto, > 1 h apart	19.7	$5 \leq x \leq 39$	38.9	$17 \leq x \leq 66$	s
Ditto, > 4 h apart	14.1	$4 \leq x \leq 27$	27.3	$12 \leq x \leq 46$	s
Intercept with own time-displaced trajectory	16.0		21.3		

1.41 to 1.53 times the mean speed, predicting correspondingly more encounters (Table 1).

An alternative to fitting a distribution and integrating is systematically to pair all observed step lengths (including with themselves), and calculate the mean relative speed for each pair by integrating (numerically or using elliptic functions) over all possible angles between them:

$$\int_0^\pi \sqrt{x_i^2 + x_j^2 - 2x_i x_j \cos \theta} \, d\theta / \pi. \quad (34)$$

The mean over all possible pairs is 1.54 times the mean speed, very close to the figure using the transformed normal distribution.

A closer look at the distribution of step lengths shows that there is no systematic variation during most of the day, but that the mean is lower in the last two evening periods, because sometimes the group had already settled down for the night. We repeated the systematic pairing of all step lengths, but this time pairing step lengths recorded at each of the latest two times of day only with others recorded at the same time. In this example this refinement made very little difference.

These calculations have all assumed that groups do not have home ranges. In fact the mangabey group had a roughly rectangular home range, bounded on its east and west sides by unsuitable habitat. Very roughly, a central area of 0.3 the length of the rectangle was used exclusively by this group and each of the ends was overlapped by the home range of another group. If we assume that usage over the home range was even and that the areas of overlap occupied a similar proportion of each neighbour's home range, then we can use formula (27) to revise our prediction of encounter rate: $2(h-1)/h^2$, where $h = 1/(0.3 + 0.35)$, implies a correction factor of 0.46, considerably reducing the predicted number of encounters (Table 1). A better prediction would incorporate the observed proportions of time that the focal group spent in the two areas of overlap: they were 0.30 and 0.37. If we continue to assume that each neighbouring group spent the same proportion of its time in each area of overlap as did the focal group, the probability of being in an area of overlap at the same time as that neighbour is now $(0.30^2 + 0.37^2)$, compared with the earlier calculation of 2×0.35^2 . This slightly reduces the correction factor to 0.42.

Now we consider how to test whether the observed number of encounters differs significantly from these predictions, which requires estimating the variance in the number of encounters. We first illustrate the second of our three proposed approaches, using the observed variation from month to month. There were too few encounters within 200 m to provide a reliable estimate of the variance. With the 500 m detection distance, there were 5 months of 0 encounters, 4 months of 1 encounter, 2 of 2, and 1 of 3. Very different distances were moved in some months, in large part due to differing lengths of observation; therefore we computed mean rate of encounter each month. A square-root transformation served to make the distribution

more normally distributed. The standard error of the mean was multiplied by the 95% confidence limit for the t_{11} distribution, added and subtracted from the mean, and back-transformed to generate confidence limits of 2–18 encounters over the 2261 half-hours of observation. So predictions outside this range should be judged as differing significantly from observations.

The other approaches to statistical testing estimate the variance from the model rather than the data. Assuming a Poisson distribution of encounters and a mean number of encounters of 29.7 or 60.5, yields 95% confidence limits of 21–38 and 48–73 for encounters at 200 and 500 m respectively (Table 1).

Unfortunately it is not appropriate to assume a Poisson distribution for the model involving overlap of home ranges; if an animal is in an exclusive part of its home range, for instance, it is likely to remain so for some time, increasing the variance in encounter rate. In any case the Poisson distribution will underestimate the variance because trajectories are not straight. Our third approach, based on simulating a more detailed model of movements allows a more valid estimate of variance for non-straight trajectories (but here we assume panmixis rather than modelling the overlapping home ranges). We chose to sample randomly from the observed step lengths and changes of angle (rather than sampling from fitted distributions). There was no need to incorporate a correlation between these because it scarcely existed in our data. Our model also matched the structure of the observations. Observations were made in blocks of typically 10 days, and since blocks were separated by typically 20 days, our model took a new random starting configuration each block. Otherwise, the initial location each day was taken as the same as the night before, but the initial direction was chosen at random. Our model matched the pattern of observation periods exactly, so that some blocks had more days than others. Similarly, although the random walk continued for 23 steps each day, on some days there were periods when data had not been recorded and accordingly any encounters in our model at the corresponding times were ignored. Using this approach, the 95% confidence limits for the number of encounters were much wider than the Poisson-generated limits (Table 1).

The simulation also allowed us to investigate one source of observer bias. Two groups that encounter each other may shortly afterwards re-encounter each other, but observers might easily not realise that there was a period when the groups were apart. We could set our simulation to ignore re-encounters starting within some period from the end of earlier encounters between the same groups. Setting this period to 1 h reduced the predicted number of 200 m encounters from 29.7 to 19.7; setting it to 4 h reduced it further to 14.1 (Table 1).

In theory the random walk could be further modified to make it more realistic. One modification that had almost no effect on the confidence limits was to incorporate the observed autocorrelation between successive step lengths and turning angles. However, that version was based on a first-order Markov process (i.e. only the immediately preceding step influences the next; Root & Kareiva, 1984),

not on consistencies in step lengths and directionality persisting over several hours. In reality the group tended to spend several days in succession feeding on the same fruiting tree in the morning and exploring away from it later in the day, whereas on other days it moved more directionally to locate a new source of fruit (Waser, 1977a). Simulating this would require much information on fruiting patterns and foraging behaviour. An easier modification to our simulation would be to simulate just the three neighbouring groups observed, restricting each to their observed home ranges.

We also tried the approach of counting intercepts with the group's own trajectory in other months (so separated by ≥ 14 days, enough for the group to traverse its home range). This null model's strength is incorporating any consistent tendency to avoid regions, perhaps of unsuitable habitat, within a home range. For the most southerly 0.35 of the home range, we selected steps starting within this region, then systematically paired all such steps from different months, and found that 0.0239 of these pairings would have involved a 200 m encounter. The focal group was in that region 0.30 of the time, and so we assume (as above) that it and its neighbour were there simultaneously 0.30^2 of the time. A total of 2261 half-hour steps were observed, so we predict $2261 \times 0.0239 \times 0.30^2$ encounters in the southern area of overlap, plus $2261 \times 0.0358 \times 0.37^2$ in the northern area of overlap, summing to 16.0 encounters. This figure and the corresponding prediction for encounters within 500 m are comparable with the predictions from the ideal gas model when range overlap is incorporated (Table 1). Apparently any tendency to avoid or prefer particular regions within the home range is at the wrong scale, or otherwise insufficient, to have much effect on the rate of encounter at these distances.

VIII. DISCUSSION

Our analyses indicate that when individuals do not interact with each other the ideal gas model makes rather robust predictions about the number of contacts, but less robust predictions about the variance of this number or the number of different individuals contacted. In addition, the model will tend to overestimate the number of encounters scored if multiple contacts within a short interval are overlooked. The model must be modified when animals are restricted to overlapping home ranges, but encounter rates are still predictable if appropriate data on home-range geometry and usage have been collected. When individuals move away from each other on contact, the model underestimates encounter rate, but not by much unless density is very high.

Reanalysis of the data set used in an early application of the ideal gas model to the investigation of grey-cheeked mangabey intergroup encounters showed that the results were insensitive to a variety of refinements (more realistic speed distributions, and allowing correlation among steps in the underlying random walk model of movement). On the other hand, both a more realistic incorporation of home-range overlap and filtering out multiple encounters over

a short interval lowered the predictions considerably, and would do so further if these modifications were combined. Also, our simulations indicate that the confidence limits around predicted encounter rates are wide, making it difficult to demonstrate statistically significant differences from observations. The confidence limits would have been even wider had we allowed for some uncertainty in the parameters used, for instance in density or in speed of other groups.

This fundamental problem of wide confidence limits may mean that counting encounters is not the best way to test whether animals avoid or are attracted to each other; for instance, Waser (1976, 1977b) relied not just on the ideal gas model, but also observed how mangabeys responded to playbacks of neighbours' calls. For other purposes the ideal gas model remains useful in providing estimates of encounter rate in a wide variety of biological interactions. A particular benefit of this analytic approach is that biologists are immediately alerted to the expected form of the relationship between speed, density or detection distance and the quantity of interest (not only encounter rate, but encounter duration, the intervals between encounters, *etc.*). The form of these relationships may indeed be what matters most when the ideal gas model is used as a component of larger models. However, simulations provide a way to add biologically interesting complications to the ideal gas model.

This may be a ripe time to reconsider the ideal gas model and its variants, because the diminishing price and size of tracking technologies (e.g. GPS data loggers and satellite tracking: Kenward *et al.*, 2002) now facilitate near-continuous recording of position however widely the animals range. These technologies not only provide parameters for the model (speed distributions, home range overlaps, *etc.*) but, because multiple animals can be tracked simultaneously, they also provide a means to monitor encounters themselves. In this latter context, another recent technological advance is data loggers that record the presence of other tagged individuals in close proximity (Weihong, White & Clout, 2005).

In reviewing the many diverse applications of the ideal gas model, we were surprised by several omissions. For example, we failed to find its application among studies of commercial fishing. The explanation appears to be that the models used to predict fish capture rates are more sophisticated than the ideal gas model, taking into account the avoidance behaviour of the fish once they notice the approaching net, and the consequent greater propensity for fish further from the centre of the net to escape (Barkley, 1964; Laval, 1974).

More difficult to explain is that we found no mention of the ideal gas model in epidemiology, despite the acknowledged importance of contact rate in determining the spread and prevalence of diseases and parasites (e.g. Gompper & Wright, 2005). Epidemiology goes as far as borrowing the law of mass action from chemistry (that the rate of contact between two types of individuals is proportional to the product of their densities; McCallum, Barlow & Hone, 2001; Begon *et al.*, 2002). This result is a prediction of the ideal gas model; what is extra in the ideal gas model itself, besides the value of the multiplicative constant, is the dependence of rate of contact on individual speeds and on

the critical distance between individuals that defines a “contact”. As an example of the possible applicability of the ideal gas model, consider the typical finding in epidemiology that infection rate shows a non-linear effect of density (Fenton *et al.*, 2002). In some cases this might be explained by looking at how individual behaviour depends on density (Dwyer & Elkinton, 1993). For instance, it might be that density affects speed of movement or the degree of overlap of home ranges; application of the ideal gas model would then allow a revision of the relationship between contact or infection rate and density. The same sorts of analysis might be used to improve models of information spread in social animals (*cf.* Adler & Gordon, 1992).

The story described in the Introduction is of biologists repeatedly and independently turning to physics to find an equation for collision frequencies between moving particles. An interesting twist to this tale is that James Clerk Maxwell, the originator of the equation for collision rate in an ideal gas, was himself inspired by research on populations of animals (humans). In the social sciences, the statistical approach had reliably described such phenomena as crime rates and ages of marriage in large populations even though behaviour of individual humans was obviously unpredictable, which stimulated both Maxwell and Boltzmann to take the same statistical approach with molecules (Gigerenzer *et al.*, 1989, p. 62).

IX. CONCLUSIONS

(1) The ideal gas model applies to non-interacting particles moving in randomly oriented straight lines. It yields a simple equation linking the number of times particles come within a specified distance of one another to their speed and density. The formula is straightforward to extend to encounters between two classes of individual differing in their densities and speeds.

(2) This encounter-rate formula is quite different to that predicting how many neighbouring particles lie within the specified distance at a single moment of observation, or summed over a series of such observations. Combining the two different formulae allows calculation of mean duration of an encounter, which published formulae overestimate.

(3) The model has been widely applied in biology to analyse rates of encounters between individuals (e.g. males and females, sperm and eggs, predators and prey, human observers and the animals that they are counting) and between groups of individuals. It has been used both as a null model to detect avoidance or association, and as a component of other models that analyse rates of events dependent on encounters.

(4) There are different versions of the formula depending on whether movement is in two or three dimensions and on whether speeds are constant or follow Maxwell-Boltzmann distributions. Versions for other speed distributions usually require numerical integration to derive the multiplicative constant. This is also the case if directions of movement are anisotropic.

(5) Local variation in density has a different effect on the predictions depending on whether it is due to individuals

avoiding low-density regions or moving faster within them. Simple extensions of the model cover the situation when density decreases progressively as a result of previous encounters (e.g. predators and prey).

(6) When individuals are restricted to home ranges that overlap, a simple correction factor may often be adequate, but this differs from corrections given in the literature.

(7) If movement is not in straight lines, the formulae still hold for mean number of encounters, but this is no longer Poisson distributed (invalidating several published calculations of whether any encounter occurs in a specified time). Many encounters will now be re-encounters with the same individual, which field observations might well not distinguish. We know of no analytic formulae for predicting the number of different individuals encountered, although this will be Poisson distributed and proportional to density.

(8) If individuals back away from one another following contact, the encounter-rate formulae produce serious underestimates only at high densities, such as might be experienced by ants in a nest. Other forms of non-independence of movement are generally not tractable.

(9) Tests of the significance of differences between model predictions and observations may be based on three approaches to estimating variance: (i) from a series of observations at different times; (ii) from the Poisson distribution (leading to too many rejections if paths are not straight); and (iii) from simulations based on a correlated random walk.

(10) A reanalysis of data on encounters between groups of grey-cheeked mangabeys tends to support the initial conclusion that groups avoid each other, but also suggests three additional factors that might contribute to the low number of observed encounters relative to predictions from the ideal gas model: (i) restricted home-range overlap of neighbours compared with panmixis, (ii) the possibility of overlooking re-encounters within an hour of an earlier encounter, and (iii) the wide confidence intervals calculated from simulations of a correlated random walk.

X. ACKNOWLEDGEMENTS

Many thanks to Greg Sandland for help in searching the epidemiological literature, to Buks van Rensburg for responding to queries about contact rates in dense gases, and to Jeff Lucas, Walter Jetz, Heike Reise and two referees for their comments on versions of the manuscript. The authors we criticise have responded in a most positive way; in particular we thank Kevin Bailey, Greg Farley, Sandy Harcourt, Margaret Kinnaird and Stam Nicolis for their comments.

XI. REFERENCES

- ADLER, F. R. & GORDON, D. M. (1992). Information collection and spread by networks of patrolling ants. *American Naturalist* **140**, 373–400.

- ALLEE, W. C. (1938). *The Social Life of Animals*. W.W. Norton, New York.
- ANDERSON, J. J., GURARIE, E. & ZABEL, R. W. (2005). Mean free-path length theory of predator-prey interactions: application to juvenile salmon migration. *Ecological Modelling* **186**, 196–211.
- BAILEY, K. M. & BATTY, R. S. (1983). A laboratory study of predation by *Aurelia aurita* on larval herring (*Clupea harengus*): experimental observations compared with model predictions. *Marine Biology* **72**, 295–301.
- BARKLEY, R. A. (1964). The theoretical effectiveness of towed-net samplers as related to sampler size and to swimming speed of organisms. *Journal du Conseil, Conseil International pour l'Exploration de la Mer* **29**, 146–157.
- BARRETT, L. & LOWEN, C. B. (1998). Random walks and the gas model: spacing behaviour of grey-cheeked mangabeys. *Functional Ecology* **12**, 857–865.
- BEGON, M., BENNETT, M., BOWERS, R. G., FRENCH, N. P., HAZEL, S. M. & TURNER, J. (2002). A clarification of transmission terms in host-microparasite models: numbers, densities and areas. *Epidemiology and Infection* **129**, 147–153.
- BENNETT, E. L. (1984). The banded langur: ecology of a colobine in West Malaysian rain-forest. Unpublished Ph.D. dissertation, University of Cambridge.
- BERGMAN, C. M., SCHAEFER, J. A. & LUTTICH, S. N. (2000). Caribou movement as a correlated random walk. *Oecologia* **123**, 364–374.
- BUCKLAND, S. T., ANDERSON, D. R., BURNHAM, K. P., LAAKE, J. L., BORCHERS, D. L. & THOMAS, L. (2001). *Introduction to Distance Sampling: Estimating Abundance of Biological Populations*. Oxford University Press, Oxford.
- CHAPMAN, S. & COWLING, T. G. (1952). *The Mathematical Theory of Non-uniform Gases*. Cambridge University Press, Cambridge, UK.
- CORDS, M. (1987). Mixed-species association of *Cercopithecus* monkeys in the Kakamega forest, Kenya. *University of California Publications in Zoology* **117**, 1–109.
- COWAN, J. H. JR & HOUDE, E. D. (1992). Size-dependent predation on marine fish larvae by ctenophores, scyphomedusae, and planktivorous fish. *Fisheries Oceanography* **1**, 113–126.
- COX, P. A. (1983). Search theory, random motion, and the convergent evolution of pollen and spore morphology in aquatic plants. *American Naturalist* **121**, 9–31.
- COX, P. A. & SETHIAN, J. A. (1985). Gamete motion, search, and the evolution of anisogamy, oogamy, and chemotaxis. *American Naturalist* **125**, 74–101.
- CROWLEY, P. H., TRAVERS, S. E., LINTON, M. C., COHN, S. L., SIH, A. & SARGENT, R. C. (1991). Mate density, predation risk, and the seasonal sequence of mate choices: a dynamic game. *American Naturalist* **137**, 567–596.
- DE VITA, J., KELLY, D. & PAYNE, S. (1982). Arthropod encounter rate: a null model based on random motion. *American Naturalist* **119**, 499–510.
- DONCASTER, C. P. (1990). Non-parametric estimates of interaction from radio-tracking data. *Journal of Theoretical Biology* **143**, 431–443.
- DUNBAR, R. I. M. (1988). *Primate Social Systems*. Croom Helm, London.
- DUNBAR, R. I. M. (1995). The mating system of callitrichid primates: I. Conditions for the coevolution of pair bonding and twinning. *Animal Behaviour* **50**, 1057–1070.
- DUNBAR, R. I. M. (2000). Male mating strategies: a modeling approach. In *Primate Males: Causes and Consequences of Variation in Group Composition* (ed. P. M. Kappeler), pp. 259–268. Cambridge University Press, Cambridge.
- DUNBAR, R. I. M. (2002). Modelling primate behavioral ecology. *International Journal of Primatology* **23**, 785–819.
- DUSENBERY, D. B. (1992). *Sensory Ecology: How Organisms Acquire and Respond to Information*. W. H. Freeman, San Francisco.
- DUSENBERY, D. B. (2000). Selection for high gamete encounter rates explains the success of male and female mating types. *Journal of Theoretical Biology* **202**, 1–10.
- DUSENBERY, D. B. (2002). Ecological models explaining the success of distinctive sperm and eggs (oogamy). *Journal of Theoretical Biology* **219**, 1–7.
- DUSENBERY, D. B. (2006). Selection for high gamete encounter rates explains the evolution of anisogamy using plausible assumptions about size relationships of swimming speed and duration. *Journal of Theoretical Biology* **241**, 33–38.
- DWYER, G. & ELKINTON, J. S. (1993). Using simple models to predict virus epizootics in gypsy moth populations. *Journal of Animal Ecology* **62**, 1–11.
- EVANS, G. T. (1989). The encounter speed of moving predator and prey. *Journal of Plankton Research* **11**, 415–417.
- FARLEY, G. S. (2002). Helical nature of sperm swimming affects the fit of fertilization-kinetics models to empirical data. *Biological Bulletin* **203**, 51–57.
- FARLEY, G. S. & LEVITAN, D. R. (2001). The role of jelly coats in sperm-egg encounters, fertilization success, and selection on egg size in broadcast spawners. *American Naturalist* **157**, 626–636.
- FENTON, A., FAIRBAIRN, J. P., NORMAN, R. & HUDSON, P. J. (2002). Parasite transmission: reconciling theory and reality. *Journal of Animal Ecology* **71**, 893–905.
- FISHER, N. I. (1993). *Statistical Analysis of Circular Data*. Cambridge University Press, Cambridge, UK.
- FUIMAN, L. A. & GAMBLE, J. C. (1989). Influence of experimental manipulations on predation of herring larvae by juvenile herring in large enclosures. *Rapports et Procès-Verbaux des Réunions du Conseil International pour l'Exploration de la Mer* **191**, 359–365.
- GASTON, A. J. & SMITH, G. E. J. (1984). The interpretation of aerial surveys for seabirds: some effects of behaviour. *Occasional Paper No. 53 Canadian Wildlife Service*.
- GASTON, A. J., COLLINS, B. L. & DIAMOND, A. W. (1987). The “snapshot” count for estimating densities of flying seabirds during boat transects: a cautionary comment. *Auk* **104**, 336–338.
- GERRITSEN, J. (1980a). Adaptive responses to encounter problems. In *Evolution and Ecology of Zooplankton Communities* (ed. W. C. Kerfoot), pp. 52–62. University Press, Hanover, NH.
- GERRITSEN, J. (1980b). Sex and parthenogenesis in sparse populations. *American Naturalist* **115**, 718–742.
- GERRITSEN, J. & STRICKLER, J. R. (1977). Encounter probabilities and community structure in zooplankton: a mathematical model. *Journal of the Fisheries Research Board of Canada* **34**, 73–82.
- GIGERENZER, G., SWIJTINK, Z., PORTER, T., DASTON, L., BEATTY, J. & KRÜGER, L. (1989). *The Empire of Chance: How Probability Changed Science and Everyday Life*. Cambridge University Press, Cambridge, UK.
- GOMPPER, M. E. & WRIGHT, A. N. (2005). Altered prevalence of raccoon roundworm (*Baylisascaris procyonis*) owing to manipulated contact rates of hosts. *Journal of Zoology* **266**, 215–219.
- GORDON, D. M., PAUL, R. E. & THORPE, K. (1993). What is the function of encounter patterns in ant colonies? *Animal Behaviour* **45**, 1083–1100.
- GURSKY, S. (2005). Associations between adult spectral tarsiers. *American Journal of Physical Anthropology* **128**, 74–83.

- HAM, R. M. (1994). Behaviour and ecology of grey-cheeked mangabey (*Cercocebus albigena*) in the Lope Reserve, Gabon. Unpublished Ph.D. dissertation, University of Stirling.
- HARCOURT, A. H. & GREENBERG, J. (2001). Do gorilla females join males to avoid infanticide? A quantitative model. *Animal Behaviour* **62**, 905–915.
- HILL, C. M. (1991). A study of territoriality in *Cercopithecus diana*. Do females take an active part in territorial defence? Unpublished D. Phil. dissertation, University College London.
- HOLENWEIG, A.-K., NOË, R. & SCHABEL, M. (1996). Waser's gas model applied to associations between red colobus and Diana monkeys in the Tai National Park, Ivory Coast. *Folia Primatologica* **67**, 125–136.
- JEFFREYS, H. (1961). *Theory of Probability* (3rd edition). Clarendon Press, Oxford.
- JETZ, W., CARBONE, C., FULFORD, J. & BROWN, J. H. (2004). The scaling of animal space use. *Science* **306**, 266–268.
- JOLLY, A., RASAMIMANANA, H. R., KINNAIRD, M. F., O'BRIEN, T. G., CROWLEY, H. M., HARCOURT, C. S., GARDNER, S. & DAVIDSON, J. M. (1993). Territoriality in *Lemur catta* groups during the birth season at Berenty, Madagascar. In *Lemur Social Systems and Their Ecological Basis* (eds P. M. Kappeler and J. U. Ganzhorn), pp. 85–109. Plenum Press, New York.
- KATONA, S. K. (1973). Evidence for sex pheromones in planktonic copepods. *Limnology and Oceanography* **18**, 574–583.
- KAUZMANN, W. (1966). *Kinetic Theory of Gases. Thermal Properties of Matter*. Volume 1. W. A. Benjamin Inc., New York.
- KENWARD, R. E., RUSHTON, S. P., PERRINS, C. M., MACDONALD, D. W. & SOUTH, A. B. (2002). From marking to modeling: dispersal study techniques for land vertebrates. In *Dispersal Ecology* (eds T. M. Bullock, R. E. Kenward and R. S. Hails), pp. 50–71. Blackwell, Oxford.
- KILTIE, R. A. (1980). Application of search theory to the analysis of prey aggregation as an antipredation tactic. *Journal of Theoretical Biology* **87**, 201–206.
- KINNAIRD, M. F. & O'BRIEN, T. G. (2000). Comparative movement patterns of two semi-terrestrial cercopithecine primates: the Tana River crested mangabey and the Sulawesi crested black macaque. In *On the Move: How and Why Animals Travel in Groups* (eds S. Boinski and P. A. Garber), pp. 327–350. University of Chicago Press, Chicago.
- KOOPMAN, B. O. (1956). The theory of search. I. Kinematic bases. *Operations Research* **4**, 324–346.
- LAING, J. (1938). Host-finding by insect parasites. II. The chance of *Trichogramma evanescens* finding its hosts. *Journal of Experimental Biology* **15**, 281–302.
- LAVAL, P. (1974). Un modèle mathématique de l'évitement d'un filet à plancton, son application pratique, et sa vérification indirecte en recourant au parasitisme de l'amphipode hypéride *Vibilia armata* Bovallius. *Journal of Experimental Marine Biology and Ecology* **14**, 57–87.
- LETCHER, B. H., RICE, J. A., CROWDER, L. B. & ROSE, K. A. (1996). Variability in survival of larval fish: disentangling components with a generalized individual-based model. *Canadian Journal of Fisheries and Aquatic Science* **53**, 787–801.
- LOFKA, A. J. (1924). *Elements of Physical Biology*. Williams and Wilkins, Baltimore.
- LOWEN, C. & DUNBAR, R. I. M. (1994). Territory size and defendability in primates. *Behavioral Ecology and Sociobiology* **35**, 347–354.
- LUDING, S. (2001). Global equation of state of two-dimensional hard sphere systems. *Physics Review E* **63**, 042201.
- MANLY, B. F. J. (1997). *Randomization, Bootstrap and Monte Carlo Methods in Biology* (2nd edition). Chapman and Hall, London.
- MAXWELL, J. C. (1860). Illustrations of the dynamical theory of gases. Part I. On the motions and collisions of perfectly elastic spheres. *Philosophical Magazine* **19**, 19–32.
- MANICA, A. & JOHNSTONE, R. A. (2004). The evolution of paternal care with overlapping broods. *American Naturalist* **164**, 517–530.
- MCCALLUM, H., BARLOW, N. & HONE, J. (2001). How should pathogen transmission be modelled? *Trends in Ecology and Evolution* **16**, 295–300.
- MITANI, J. C., GREYER, G. F., RODMAN, P. S. & PRIATNA, D. (1991). Associations among wild orang-utans: sociality, passive aggregations or chance? *Animal Behaviour* **42**, 33–46.
- MOSIMANN, J. E. (1958). The evolutionary significance of rare matings in animal populations. *Evolution* **12**, 246–261.
- NICOLIS, S. C., THERAULAZ, G. & DENEUBOURG, J. L. (2005). The effects of aggregates on interaction rate in ant colonies. *Animal Behaviour* **69**, 535–540.
- OKUBO, A. (1980). *Diffusion and Ecological Problems: Mathematical Models*. Springer-Verlag, Berlin.
- OLSON, F. C. W. (1964). The survival value of fish schooling. *Journal du Conseil, Conseil Permanent International pour l'Exploration de la Mer* **29**, 115–116.
- PARADIS, A. R. & PEPIN, P. (2001). Modelling changes in the length-frequency distributions of fish larvae using field estimates of predator abundance and size distributions. *Fisheries Oceanography* **10**, 217–234.
- PARADIS, A. R., PÉPIN, M. & PEPIN, P. (1999). Disentangling the effects of size-dependent encounter and susceptibility to predation with an individual-based model for fish larvae. *Canadian Journal of Fisheries and Aquatic Science* **56**, 1562–1575.
- PODOLSKY, R. D. (2002). Fertilization ecology of egg coats: physical versus chemical contributions to fertilization success of free-spawned eggs. *Journal of Experimental Biology* **205**, 1657–1668.
- PRATT, S. C. (2005). Quorum sensing by encounter rates in the ant *Temnothorax albipennis*. *Behavioral Ecology* **16**, 488–496.
- RANDERSON, J. P. & HURST, L. D. (2001). The uncertain evolution of the sexes. *Trends in Ecology and Evolution* **16**, 571–579.
- ROOT, R. B. & KAREIVA, P. M. (1984). The search for resources by cabbage butterflies (*Pieris rapae*): ecological consequences and adaptive significance of Markovian movements in a patchy environment. *Ecology* **65**, 147–165.
- ROSENTHAL, H. & HEMPEL, G. (1970). Experimental studies in feeding and food requirements of herring larvae (*Clupea harengus* L.). In *Marine Food Chains* (ed. J. H. Steele), pp. 344–364. University of California Press, Berkeley.
- ROWCLIFFE, J. M., COWLISHAW, G. & LONG, J. (2003). A model of human hunting impacts in multi-prey communities. *Journal of Applied Ecology* **40**, 872–889.
- SCHÜLKE, O. & KAPPELER, P. M. (2003). So near and yet so far: territorial pairs but low cohesion between pair partners in a nocturnal lemur, *Phaner furcifer*. *Animal Behaviour* **65**, 331–343.
- SCUDO, F. M. (1967). The adaptive value of sexual dimorphism: I, anisogamy. *Evolution* **21**, 285–291.
- SKELLAM, J. G. (1958). The mathematical foundations underlying the use of line transects in animal ecology. *Biometrics* **14**, 385–400.
- SPEAR, L., NUR, N. & AINLEY, D. G. (1992). Estimating absolute densities of flying seabirds using analyses of relative movement. *Auk* **109**, 385–389.

- STANLEY, J. (1932). A mathematical theory of the growth of populations of the flour beetle, *Tribolium confusum*, Duv. *Canadian Journal of Research* **6**, 632–671.
- STRUHSAKER, T. T. (1981). Polyspecific associations among tropical rain-forest primates. *Zeitschrift für Tierpsychologie* **57**, 268–304.
- SUGIURA, H., SAITO, C., SATO, S., AGETSUMA, N., TAKAHASHI, H., TANAKA, T., FURUICHI, T. & TAKAHATA, Y. (2000). Variation in intergroup encounters in two populations of Japanese macaques. *International Journal of Primatology* **21**, 519–535.
- TASKER, M. L., JONES, P. H., DIXON, T. & BLAKE, B. F. (1984). Counting seabirds at sea from ships: a review of methods employed and a suggestion for a standardized approach. *Auk* **101**, 567–577.
- TRAVIS, J. M. J. & PALMER, S. C. F. (2005). Spatial processes can determine the relationship between prey encounter rate and prey density. *Biology Letters* **1**, 136–138.
- VAN RENSBURG, E. J. J. (1993). Virial coefficients for hard discs and hard spheres. *Journal of Physics A: Mathematical and General* **26**, 4805–4818.
- VAN SCHAIK, C. P. (1999). The socioecology of fission-fusion sociality in orangutans. *Primates* **40**, 69–86.
- VAN SCHAIK, C. P. & DUNBAR, R. I. M. (1990). The evolution of monogamy in large primates: a new hypothesis and some crucial tests. *Behaviour* **115**, 30–62.
- VAN SCHAIK, C. P., VAN AMERONGEN, A. & MOUTON, J. W. (1985). The organization of range use in Sumatran long-tailed macaques. In *The Socio-ecology of Sumatran Long-tailed Macaques (Macaca fascicularis): 1. Costs and Benefits of Group Living* (ed. C. P. van Schaik), pp 23–63. Elinkwijk BV, Utrecht.
- VOGEL, H., CZIHAK, G., CHANG, P. & WOLF, W. (1982). Fertilization kinetics of sea urchin eggs. *Mathematical Biosciences* **58**, 189–216.
- WASER, P. M. (1975). Spatial associations and social interactions in a “solitary” ungulate: the bushbuck *Tragelaphus scriptus* (Pallas). *Zeitschrift für Tierpsychologie* **37**, 24–36.
- WASER, P. M. (1976). *Cercocebus albigena*: site attachment, avoidance, and intergroup spacing. *American Naturalist* **110**, 911–935.
- WASER, P. (1977a). Feeding, ranging and group size in the mangabey *Cercocebus albigena*. In *Primate Ecology: Studies of Feeding and Ranging Behaviour in Lemurs, Monkeys and Apes* (ed. T. H. Clutton-Brock), pp. 183–222. Academic Press, London.
- WASER, P. (1977b). Individual recognition, intragroup cohesion and intergroup spacing: evidence from sound playback to forest monkeys. *Behaviour* **60**, 28–74.
- WASER, P. M. (1982). Primate polyspecific associations: do they occur by chance? *Animal Behaviour* **30**, 1–8.
- WASER, P. M. (1984). “Chance” and mixed-species associations. *Behavioral Ecology and Sociobiology* **15**, 197–202.
- WASER, P. M. (1987). Interactions among primate species. In *Primate Societies* (eds. B. B. Smuts, D. L. Cheney, R. M. Seyfarth, R. W. Wrangham and T. T. Struhsaker), pp. 210–226. University of Chicago Press, Chicago.
- WEIHONG, J., WHITE, P. C. L. & CLOUT, M. N. (2005). Contact rates between possums revealed by proximity data loggers. *Journal of Applied Ecology* **42**, 595–604.
- WHITESIDES, G. H. (1989). Interspecific associations of Diana monkeys, *Cercopithecus diana*, in Sierra Leone, West Africa: biological significance or chance? *Animal Behaviour* **37**, 760–776.
- YAPP, W. B. (1956). The theory of line transects. *Bird Study* **3**, 93–104.